



Monday, March 23, 2026

Agenda for the Regular Meeting of the City Council of the City of Manchester

The City Council meeting will start at 5:15 PM

Location: 204 East Main Street

1. Opening

- 1.1. Call to Order
- 1.2. Pledge of Allegiance
- 1.3. Roll Call
- 1.4. Approval of the Agenda
- 1.5. Presentation of Certificate of Appreciation to K-9 Officer Ace as he retires from the Manchester Police Department

2. Public Input

Public Input: Please state your name and address for the record before proceeding with your comments. Individual remarks are limited to 5 minutes, with the overall Public Input period limited to 30 minutes. Under Iowa Open Meetings Law, the City Council can take no formal action on comments given during the Public Input period which do not relate to Action Items on the agenda.

3. Consent Agenda

- 3.1. Approval of the minutes of the March 2, 2026 Special City Council meeting & Committee of the Whole meeting; minutes of the March 7, 2026 Special City Council meeting; minutes of the March 9, 2026 Regular City Council meeting
- 3.2. R-032-2026 Resolution Approving Payment of Bills
- 3.3. Acknowledge receipt of the following City Reports & Minutes: minutes of the March 17, 2026 Parks & Recreation Commission meeting; minutes of the February 12, 2026 Library Board meeting; minutes of the March 4, 2026 Planning & Zoning Commission meeting; the February 2026 Wastewater IDNR Reports
- 3.4. Approve payment of the following Commercial Incentive Grant: Acquisition Grant in the amount \$3,145.50 for East End Collision at 945 East Main Street
- 3.5. R-033-2026 Resolution Setting Date for Public Hearing on Urban Renewal Plan Amendment for the Manchester Urban Renewal Area
- 3.6. R-034-2026 Resolution Amending Salary Resolution
- 3.7. Approve payment of claim totaling \$938.00 to Metrics Architecture for the Baum Park Shelter Project
- 3.8. Approval of the request of the Delaware County Sexual Assault Response Team to light the West Marion Street Bridge with teal lights in April for Sexual Assault Awareness Month
- 3.9. Approval of setting April 27, 2026 at 5:00pm as the date and time for a Public Hearing on the

Proposed Budget for Fiscal Year 2027

4. Items Removed from the Consent Agenda

5. Public Hearings

- 5.1. Public Hearing on the Plans, Specifications, Form of Contract and Estimated Cost for the Grand Avenue Trail Project
- 5.2. Consider approval of Resolution R-035-2026 Approving and Confirming Plans, Specifications, Form of Contract and Estimate of Cost for the Grand Avenue Trail Project

6. Regular Agenda Items

- 6.1. Consider approval of Resolution R-036-2026 Authorizing and Approving a Loan Agreement, Providing for the Issuance of \$2,000,000 General Obligation Corporate Purpose Bonds, Series 2026, and Providing for the Levy of Taxes to Pay the Same
- 6.2. Consider approval of a Letter of Intent & Project Assurances Form Supporting the Submission of the 2026 Community Catalyst Building Remediation Program Grant Application of RAMM Properties for the building at 116 South Franklin Street
- 6.3. Consider approval of the second consideration & adoption of Ordinance 002-2026 Amending the City Code of the City of Manchester by Amending Chapter 55 Animal Protection & Control
- 6.4. Consider approval of the second consideration & adoption of Ordinance 003-2026 Amending the City Code of the City of Manchester by Amending Provisions pertaining to Parking Violations
- 6.5. Consider approval of the Request for Special Exception to Livestock Restrictions from Ethan Uhrig to allow for 6-8 chickens on the property at 500 East Prospect Street

7. Engineer Updates

8. Reports

- 8.1. City Attorney
- 8.2. City Manager
- 8.3. City Clerk
- 8.4. Police Chief
- 8.5. City Council Members
- 8.6. Mayor

9. Information/Upcoming Meetings

10. Adjourn

Minutes of the Special Meeting & Committee of the Whole Meeting of the City Council of the
City of Manchester, Iowa
Monday, March 2, 2026

Video recordings of City Council meetings are available at
<https://www.youtube.com/@cityofmanchesteriowa9648>

Mayor Behnken called the meeting to order at 5:00pm.

Roll call of members present: Bill Scherbring, Joe Dittrick, Mary Ann Poynor, Diane Hammell, Bryan Gray. Absent: None.

Also present: Alison Hegland, Doug Foley, Chad Wulfekuhle, Jason Haight, Tim Heims, Perry Peterson, Randy Rattenborg, Sam Ertl, Jason Wenger, Wes Schulte.

SPECIAL MEETING

Motion by Scherbring, seconded by Poynor to approve Resolution R-026-2026 Approving Contract and Performance and/or Payment Bonds for the Anderson Street Improvements Project. On call of roll: Ayes: Scherbring, Poynor, Hammell, Gray, Dittrick. Nays: None. Motion carried.

COMMITTEE OF THE WHOLE MEETING

Wes Schulte discussed with the City Council his Lincoln school redevelopment proposal. The City Council discussed with City Staff the following items: proposed parking violation fine changes, parks and street equipment, proposed update to the City Code to address animal waste, publication timeframe proposed changes, and the fiscal year 2027 budget. Engineering, City Staff and City Council updates were given.

Motion by Hammell, seconded by Poynor that the meeting adjourn at 6:41pm. Motion carried, all ayes.

Connie Behnken, Mayor

Erin Learn, City Clerk

Minutes of the Special Meeting of the City Council of the City of Manchester, Iowa
Saturday, March 7, 2026

Video recordings of City Council meetings are available at
<https://www.youtube.com/@cityofmanchesteriowa9648>

Mayor Behnken called the special meeting to order at 12:42pm.

Roll call of members present: Joe Dittrick, Mary Ann Poynor, Bill Scherbring, Bryan Gray, Diane Hammell.
Absent: None.

CLOSED SESSION

Motion by Gray, seconded by Poynor to enter into Closed Session at 12:43pm as provided in Section 21.5(1)(i) of the Code of Iowa to evaluate the professional competency of an individual whose appointment, hiring, performance, or discharge is being considered when necessary to prevent needless and irreparable injury to that individual's reputation and that individual requests a closed session. On call of roll: Ayes: Gray, Poynor, Scherbring, Dittrick, Hammell. Nays: None. Motion carried.

The City Council returned to open session at 1:38pm.

Motion by Scherbring, seconded by Gray that the meeting adjourn at 1:38pm. Motion carried, all ayes.

Connie Behnken, Mayor

ATTEST:

Erin Learn, City Clerk

Minutes of the Regular Meeting of the City Council of the City of Manchester, Iowa
Monday, March 9, 2026

Video recordings of City Council meetings are available at
<https://www.youtube.com/@cityofmanchesteriowa9648>

Mayor Pro Tem Poynor called the meeting to order at 5:00pm. The meeting began with the Pledge of Allegiance.

ROLL CALL

Council Members Present: Diane Hammell, Joe Dittrick, Mary Ann Poynor, Bill Scherbring. Absent: Mayor Connie Behnken, Bryan Gray.

APPROVAL OF THE AGENDA

Learn asked that the March 2, 2026 Special City Council meeting & Committee of the Whole meeting minutes be removed from Consent Agenda Item 3.1 as they were not included. Motion by Hammell, seconded by Scherbring to approve the agenda as amended, removing the March 2, 2026 minutes from Consent Agenda Item 3.1. On call of roll: Ayes: Hammell, Scherbring, Dittrick, Poynor. Nays: None. Motion carried.

PUBLIC INPUT

None.

CONSENT AGENDA

3.1 Approval of the following City Council minutes: the February 23, 2026 Regular City Council meeting; ~~the March 2, 2026 Special City Council meeting & Committee of the Whole meeting~~

3.2 R-027-2026 Resolution Approving Payment of Bills

3.3 Acknowledge receipt of the following City Reports & Minutes: 2025 Water Department Annual Report; 2025 Sewer Department Annual Report; minutes of the February 17, 2026 Forestry Committee meeting; minutes of the February 17, 2026 Parks & Recreation Commission meeting

3.4 R-028-2026 Resolution Amending Salary Resolution

3.5 Approve the following Downtown/Commercial Incentive Grant Applications as recommended by the Design Committee: Acquisition Grant in the amount of \$3,145.50, Interior Grant in the amount of \$4,606.64 & Facade Grant in the amount of \$168.75 for East End Collision at 945 East Main Street; Interior Grant in the amount of \$3,554.29, Facade Grant (south facade) in the amount of \$2,590.21 & Facade Grant (west facade) in the amount of \$525.00 plus a third of the window cost for Franklin Fresh Laundromat at 211 North Franklin Street; Facade Grant (east facade) in the amount of \$7,500.00, Facade Grant (north facade) in the amount of \$280.07 & Interior Grant in the amount of \$2,520.99 for The Quiltmakers Shoppe at 120 North Franklin Street

3.6 Approve payment of the following Downtown Incentive Grant: Facade Grant (east facade) in the amount of \$7,500.00, Facade Grant (south facade) in the amount of \$7,500.00 for Schmitz Properties LLC at 100 North Franklin Street; Facade Grant in the amount of \$7,500.00 for Schmitz Properties LLC at 104 North Franklin Street

3.7 Approve payment of claims totaling \$5,605.35 to Fehr Graham for engineering services

3.8 Approval of the second consideration & adoption of Ordinance 001-2026 An Ordinance Amending the Official Zoning Map of the City of Manchester, Iowa (401 Lincoln Street)

Mayor Pro Tem Poynor reviewed the items on the Consent Agenda with the City Council. Motion by Dittrick, seconded by Scherbring to approve the Consent Agenda. On call of roll: Ayes: Dittrick, Scherbring, Hammell, Poynor. Nays: None. Motion carried.

Bills approved for payment:

Vendor	Description	Amount
Accent Laser	Toner cartridges	344.80
Access Systems	Copier leasing/services	489.49
ALCO Pro	Equipment repair/maintenance	605.50
Alliant	Electricity	2,122.21
Amazon Business	Supplies	2,867.84
Anderson Welding	Repairs	57.76
Arnold Motor Supply	Vehicle parts/repairs	290.52
AT&T	Hotspot/telecom services	50.15
Bard Materials	Rock	610.57
BASE	Benefits administration	268.00
Black Hawk Automatic Sprinkler	Backflow prevention service	265.00
Boubin Tire & Automotive	Vehicle repair	3,204.41
Casandra Orr	Street project payment	705.00
Cathy Westhoff	Street project payment	142.50
City Laundering	Rug cleaning/maintenance	144.43
Comelec	Internet service	153.00
Conway Shield	Fire equipment maintenance	1,880.00
Copy Systems	Copier repair	182.55
Critter Getter	Animal control services	1,075.00
Crystal & Paul McMullen	Street project payment	625.00
Curtis Blue Line	Police equipment/uniforms	780.00
Danko	Training equipment	1,493.00
Darlene Boge	Street project payment	700.00
Del Co Solid Waste Commission	Landfill charges	1,040.90
Dianne Williams	Street project payment	142.50
ECIA	Keep Iowa Beautiful program	2,000.00
EMS Industrial	Equipment purchase	313.72
Engineered Equipment Solutions	Wastewater repairs	1,371.90
Fantasy Drone Shows	Drone event	12,500.00
Fareway Stores	Supplies	132.00
Fehr Graham	Engineering services	8,211.75
Georgen Auto	Vehicle maintenance	3,097.97
Gloria Kluesner	Street project payment	772.50
Hausers Water Systems	Water supplies	20.00
IA Public Airports Association	Membership dues	125.00
Infrastructure Technology	IT maintenance	195.00
Ingram Library Services	Library materials	12.66
Janet Marbach	Street project payment	290.00
Jasmine White	Maintenance services	80.00
Jeremy Sickels	Street project payment	367.50
John Deere Financial	Supplies	365.14
Joyce Edmonds	Street project payment	770.00
Kluesner Flooring	Flooring repair	75.00
Kluesner Sanitation	Garbage/recycling contract	28,626.91

Kory Young	Street project payment	1,085.00
Library Ideas	Library materials	149.48
Lindsay Darling	Street project payment	142.50
Maggie Sommers	Website maintenance	800.00
Manchester Animal Medical	Veterinary services	212.00
Mark Fink	Snow removal	600.00
Masterpiece Cleaning	Custodial services	800.00
Mediacom	Internet service	11.22
Microbac Laboratories	Lab testing	112.75
Mid States Organized Crime	Membership dues	100.00
Morton Salt	Road salt	6,381.79
Municipal Supply	Meters/supplies	2,608.00
Nathan & Amy Sickels	Street project payment	367.50
Nicholas & Ashley Bente	Street project payment	225.00
Palmer Hardware	Supplies	626.50
Perry Peterson	Training/travel	63.04
Pitney Bowes	Postage/ink	91.29
Price Electric	Building repairs	105.00
Radio Communications	Vehicle repair	525.00
Regional Medical Center	EMS supplies	144.40
River City Stone	Sand	509.60
Sarah Taylor Marketing	Marketing services	759.00
Schmitz Janitorial Supply	Janitorial supplies	445.00
Sector Technology Group	IT equipment purchase	15,000.00
Shawn & Perry Bromen	Street project payment	600.00
Simmering Cory	Codification services	475.00
Smoke Eater Publications	Subscription	25.00
Star Equipment	Equipment purchase	6,430.00
Stericycle/Shred-It	Shredding services	73.56
Storey Kenworthy	Office supplies	526.32
Three Rivers FS	Vehicle fuel	3,780.77
Tree Town Kennels	Police canine purchase	6,500.00
USPS	Postage	1,223.26
Valley Athletic Field Solutions	Recreation supplies	664.90
Walmart	Supplies	94.92
Wertjes Uniforms	Uniform supplies	1,135.30
WIN LLC	Telecom services	336.70
Windstream	Telecom services	522.64
	Total	133,819.62
	Fund Totals	
	General Fund	71,500.46
	Hotel Motel Tax	14,059.00
	Road Use Tax	9,472.24
	Employee Benefits	268.00
	Library Gift & Trust	323.84

	Police Canine	7,003.92
	Street Projects	11,147.75
	Water Fund	11,403.93
	Water Capital Improvements	3,999.00
	Sewer Fund	4,641.48
	Total	133,819.62

SHOVER’S HIGHWAY #20 SUBDIVISION

Motion by Dittrick, seconded by Hammell to approve Resolution R-030-2026 Approving Final Plat for Shover's Highway #20 Subdivision. On call of roll: Ayes: Dittrick, Hammell, Scherbring, Poynor. Nays: None. Motion carried.

RESOLUTION R-029-2026 AWARDING GENERAL OBLIGATION CORPORATE PURPOSE BONDS, SERIES 2026
Maggie Burger, Speer Financial, reviewed the results of the bond sale and recommended awarding the bonds to BOK Financial. She noted that a premium was offered to effectively reduce the interest rate, with the bonds structured at 4%. Four bids were received, all of which were strong. Motion by Scherbring, seconded by Hammell to approve Resolution R-029-2026 Awarding General Obligation Corporate Purpose Bonds, Series 2026. On call of roll: Ayes: Scherbring, Hammell, Dittrick, Poynor. Nays: None. Motion carried.

PURCHASE OF A NEW JOHN DEERE SUB-COMPACT UTILITY TRACTOR

Parks & Recreation Director Doug Foley reviewed the request for the purchase of a new John Deere sub-compact utility tractor, noting that the lowest quote was received from Bodensteiner Implement Co. in the amount of \$38,900. Learn confirmed the purchase was included in the budget for this fiscal year. Motion by Hammell, seconded by Dittrick to approve the purchase of a new John Deere sub-compact utility tractor from Bodensteiner with the lowest quote was from Bodensteiner Implement Co. at a price of \$38,900. On call of roll: Ayes: Hammell, Dittrick, Scherbring, Poynor. Nays: None. Motion carried.

BAUM PARK SHELTER & RESTROOM RENOVATION PROJECT BIDS

Parks & Recreation Director Doug Foley reviewed the bids received for the Baum Park Project, noting the low bid was received from Loecke Building Services in the amount of \$143,750. Learn reviewed the proposed funding for the project with the City Council. Motion by Hammell, seconded by Scherbring to accept the Loecke Building Services bid in the amount of \$143,750 for the Baum Park Shelter and Restroom Renovation Project. On call of roll: Ayes: Hammell, Scherbring, Dittrick, Poynor. Nays: None. Motion carried.

ORDINANCE 002-2026 AMENDING THE CITY CODE OF THE CITY OF MANCHESTER BY AMENDING CHAPTER 55 ANIMAL PROTECTION & CONTROL

Motion by Scherbring, seconded by Dittrick to approve the first consideration & adoption of Ordinance 002-2026 Amending the City Code of the City of Manchester by Amending Chapter 55 Animal Protection & Control. On call of roll: Ayes: Scherbring, Dittrick, Hammell, Poynor. Nays: None. Motion carried.

ORDINANCE 003-2026 AMENDING THE CITY CODE OF THE CITY OF MANCHESTER, IOWA BY AMENDING PROVISIONS PERTAINING TO PARKING VIOLATIONS

Motion by Scherbring, seconded by Hammell to approve the first consideration & adoption of Ordinance 003-2026 Amending the City Code of the City of Manchester, Iowa by Amending Provisions Pertaining to Parking Violations. On call of roll: Ayes: Scherbring, Hammell, Dittrick, Poynor. Nays: None. Motion carried.

CITY MANAGER EMPLOYMENT AGREEMENT

Motion by Dittrick, seconded by Hammell to approve Resolution R-031-2026 Approving City Manager Employment Agreement with Brock Waters. On call of roll: Ayes: Dittrick, Hammell, Scherbring, Poynor. Nays: None. Motion carried.

ENGINEER UPDATES

Jason Wenger, Burrington Group, and Sam Ertl, Fehr Graham, updated the City Council on construction projects in the City.

REPORTS

City Staff and City Council reports were given.

Motion by Scherbring, seconded by Dittrick that the meeting adjourn at 5:47pm. Motion carried, all ayes.

Connie Behnken, Mayor

ATTEST:

Erin Learn, City Clerk

R-032-2026
RESOLUTION APPROVING PAYMENT OF BILLS

BE IT RESOLVED by the City Council of the City of Manchester, Iowa, that the list of claims, attached hereto, be approved and payment authorized.

PASSED AND APPROVED this 23rd day of March, 2026.

Connie Behnken, Mayor

Erin Learn, City Clerk



Manchester, IA

Expense Approval Report

By Vendor Name

Payment Dates 3/6/2026 - 3/19/2026

Vendor Name	Description (Payable)	Account Name	Amount
Vendor: 00037 - ALLIANT ENERGY			
Fund: 001 - GENERAL			
Department: 110 - POLICE			
ALLIANT ENERGY	ELECTRICITY	ELECTRICITY	227.81
		Department 110 - POLICE Total:	227.81
Department: 130 - EMERGENCY MANAGEMENT			
ALLIANT ENERGY	ELECTRICITY	ELECTRICITY	20.00
		Department 130 - EMERGENCY MANAGEMENT Total:	20.00
Department: 150 - FIRE			
ALLIANT ENERGY	ELECTRICITY	ELECTRICITY	87.92
		Department 150 - FIRE Total:	87.92
Department: 230 - STREET LIGHTING			
ALLIANT ENERGY	ELECTRICITY	STREET LIGHTING ELECTRICITY	7,833.37
		Department 230 - STREET LIGHTING Total:	7,833.37
Department: 280 - AIRPORT			
ALLIANT ENERGY	ELECTRICITY	ELECTRICITY	288.35
		Department 280 - AIRPORT Total:	288.35
Department: 430 - PARKS & RECREATION			
ALLIANT ENERGY	ELECTRICITY	ELECTRICITY	201.04
		Department 430 - PARKS & RECREATION Total:	201.04
Department: 620 - CITY ADMINISTRATION			
ALLIANT ENERGY	ELECTRICITY	ELECTRICITY	323.21
		Department 620 - CITY ADMINISTRATION Total:	323.21
		Fund 001 - GENERAL Total:	8,981.70
Fund: 110 - ROAD USE TAX			
Department: 210 - STREETS			
ALLIANT ENERGY	ELECTRICITY	ELECTRICITY	477.32
		Department 210 - STREETS Total:	477.32
		Fund 110 - ROAD USE TAX Total:	477.32
Fund: 600 - WATER			
Department: 810 - WATER			
ALLIANT ENERGY	ELECTRICITY	ELECTRICITY	1,701.10
		Department 810 - WATER Total:	1,701.10
		Fund 600 - WATER Total:	1,701.10
Fund: 610 - SEWER			
Department: 815 - SEWER			
ALLIANT ENERGY	ELECTRICITY	ELECTRICITY	6,909.16
		Department 815 - SEWER Total:	6,909.16
		Fund 610 - SEWER Total:	6,909.16
		Vendor 00037 - ALLIANT ENERGY Total:	18,069.28
Vendor: 00046 - AMAZON BUSINESS			
Fund: 001 - GENERAL			
Department: 410 - LIBRARY			
AMAZON BUSINESS	LIB SUPPLIES	PROGRAMS/EVENTS	23.88
AMAZON BUSINESS	LIB SUPPLIES	LIBRARY MATERIALS	325.44
AMAZON BUSINESS	LIB BOOKS	LIBRARY MATERIALS	307.58
		Department 410 - LIBRARY Total:	656.90

Expense Approval Report

Payment Dates: 3/6/2026 - 3/19/2026

Vendor Name	Description (Payable)	Account Name	Amount
Department: 430 - PARKS & RECREATION			
AMAZON BUSINESS	TIRRILL PARK LIGHT BULB	BUILDING/GROUNDS	47.00
		Department 430 - PARKS & RECREATION Total:	47.00
		Fund 001 - GENERAL Total:	703.90
Fund: 171 - LIBRARY GIFT & TRUST			
Department: 410 - LIBRARY			
AMAZON BUSINESS	LIB BOOKS	LIBRARY MATERIALS	125.44
		Department 410 - LIBRARY Total:	125.44
		Fund 171 - LIBRARY GIFT & TRUST Total:	125.44
Fund: 180 - POLICE CANINE			
Department: 110 - POLICE			
AMAZON BUSINESS	PD RETURN	OPERATING SUPPLIES	-54.99
		Department 110 - POLICE Total:	-54.99
		Fund 180 - POLICE CANINE Total:	-54.99
Fund: 610 - SEWER			
Department: 815 - SEWER			
AMAZON BUSINESS	FLASH DRIVES	SEWER MAINT/REPAIR	38.97
		Department 815 - SEWER Total:	38.97
		Fund 610 - SEWER Total:	38.97
		Vendor 00046 - AMAZON BUSINESS Total:	813.32
Vendor: 00113 - ARNOLD MOTOR SUPPLY LLP			
Fund: 610 - SEWER			
Department: 815 - SEWER			
ARNOLD MOTOR SUPPLY LLP	AIR HANDLING UNIT BELTS	MINOR EQUIPMENT	29.74
		Department 815 - SEWER Total:	29.74
		Fund 610 - SEWER Total:	29.74
		Vendor 00113 - ARNOLD MOTOR SUPPLY LLP Total:	29.74
Vendor: 01439 - CENGAGE LEARNING			
Fund: 171 - LIBRARY GIFT & TRUST			
Department: 410 - LIBRARY			
CENGAGE LEARNING	LIB BOOKS	LIBRARY MATERIALS	165.04
CENGAGE LEARNING	LIB BOOK	LIBRARY MATERIALS	23.39
CENGAGE LEARNING	LIB BOOK/WILSON DONATION	LIBRARY MATERIALS	24.04
		Department 410 - LIBRARY Total:	212.47
		Fund 171 - LIBRARY GIFT & TRUST Total:	212.47
		Vendor 01439 - CENGAGE LEARNING Total:	212.47
Vendor: 02055 - CINDY RIES			
Fund: 001 - GENERAL			
Department: 410 - LIBRARY			
CINDY RIES	SUMMER READING SUMMIT	TRAINING/TRAVEL	52.50
		Department 410 - LIBRARY Total:	52.50
		Fund 001 - GENERAL Total:	52.50
		Vendor 02055 - CINDY RIES Total:	52.50
Vendor: 00234 - CITY LAUNDERING INC			
Fund: 110 - ROAD USE TAX			
Department: 210 - STREETS			
CITY LAUNDERING INC	SHOP FIRST AID	OFFICE SUPPLIES	56.82
		Department 210 - STREETS Total:	56.82
		Fund 110 - ROAD USE TAX Total:	56.82

Expense Approval Report

Payment Dates: 3/6/2026 - 3/19/2026

Vendor Name	Description (Payable)	Account Name	Amount
Fund: 610 - SEWER Department: 815 - SEWER CITY LAUNDERING INC	WWTP FIRST AID	OPERATING SUPPLIES	64.19
		Department 815 - SEWER Total:	64.19
		Fund 610 - SEWER Total:	64.19
		Vendor 00234 - CITY LAUNDERING INC Total:	121.01
Vendor: 01914 - CONNECTIONS INC EAP Fund: 112 - EMPLOYEE BENEFITS Department: 699 - OTHER GENERAL GOVERNMENT CONNECTIONS INC EAP	EMPLOYEE ASSISTANCE PROG...	REFUNDS/MISC	164.67
		Department 699 - OTHER GENERAL GOVERNMENT Total:	164.67
		Fund 112 - EMPLOYEE BENEFITS Total:	164.67
		Vendor 01914 - CONNECTIONS INC EAP Total:	164.67
Vendor: 00336 - DELAWARE COUNTY AUDITOR Fund: 324 - STREET PROJECTS Department: 210 - STREETS DELAWARE COUNTY AUDITOR	FY26 GIS PAYMENT	PROFESSIONAL/LEGAL FEES	10,000.00
		Department 210 - STREETS Total:	10,000.00
		Fund 324 - STREET PROJECTS Total:	10,000.00
		Vendor 00336 - DELAWARE COUNTY AUDITOR Total:	10,000.00
Vendor: 00343 - DELAWARE COUNTY EMS Fund: 168 - PARK GIFT & TRUST Department: 430 - PARKS & RECREATION DELAWARE COUNTY EMS	2025 HERO HUSTLE RACE PRO...	HERO HUSTLE EXPENSES	4,500.00
		Department 430 - PARKS & RECREATION Total:	4,500.00
		Fund 168 - PARK GIFT & TRUST Total:	4,500.00
		Vendor 00343 - DELAWARE COUNTY EMS Total:	4,500.00
Vendor: 01616 - DELAWARE FIRE DEPARTMENT Fund: 168 - PARK GIFT & TRUST Department: 430 - PARKS & RECREATION DELAWARE FIRE DEPARTMENT	2025 HERO HUSTLE PUBLIC SA...	HERO HUSTLE EXPENSES	500.00
		Department 430 - PARKS & RECREATION Total:	500.00
		Fund 168 - PARK GIFT & TRUST Total:	500.00
		Vendor 01616 - DELAWARE FIRE DEPARTMENT Total:	500.00
Vendor: 00362 - DELHI LUMBER Fund: 001 - GENERAL Department: 430 - PARKS & RECREATION DELHI LUMBER	BAUM PARK ARCHES	BUILDING/GROUNDS	205.20
		Department 430 - PARKS & RECREATION Total:	205.20
		Fund 001 - GENERAL Total:	205.20
		Vendor 00362 - DELHI LUMBER Total:	205.20
Vendor: 00399 - DON & WALT LLC Fund: 610 - SEWER Department: 815 - SEWER DON & WALT LLC	WWTP MAIN OFFICE HEATER	BUILDING/GROUNDS	97.00
		Department 815 - SEWER Total:	97.00
		Fund 610 - SEWER Total:	97.00
		Vendor 00399 - DON & WALT LLC Total:	97.00

Expense Approval Report

Payment Dates: 3/6/2026 - 3/19/2026

Vendor Name	Description (Payable)	Account Name	Amount
Vendor: 00432 - EARLVILLE FIRE DEPARTMENT			
Fund: 168 - PARK GIFT & TRUST			
Department: 430 - PARKS & RECREATION			
EARLVILLE FIRE DEPARTMENT	2025 HERO HUSTLE PUBLIC SA...	HERO HUSTLE EXPENSES	500.00
		Department 430 - PARKS & RECREATION Total:	500.00
		Fund 168 - PARK GIFT & TRUST Total:	500.00
		Vendor 00432 - EARLVILLE FIRE DEPARTMENT Total:	500.00
Vendor: 00464 - EMS INDUSTRIAL INC			
Fund: 610 - SEWER			
Department: 815 - SEWER			
EMS INDUSTRIAL INC	WASTEWATER SUPPLIES	EQUIP REPAIR/MAINT	267.08
		Department 815 - SEWER Total:	267.08
		Fund 610 - SEWER Total:	267.08
		Vendor 00464 - EMS INDUSTRIAL INC Total:	267.08
Vendor: 00465 - ENGINEERED EQUIPMENT SOLUTIONS			
Fund: 610 - SEWER			
Department: 815 - SEWER			
ENGINEERED EQUIPMENT SO...	UV SUPPLIES	OPERATING SUPPLIES	2,984.30
		Department 815 - SEWER Total:	2,984.30
		Fund 610 - SEWER Total:	2,984.30
		Vendor 00465 - ENGINEERED EQUIPMENT SOLUTIONS Total:	2,984.30
Vendor: 00490 - FAREWAY STORES INC			
Fund: 001 - GENERAL			
Department: 699 - OTHER GENERAL GOVERNMENT			
FAREWAY STORES INC	WATER	PROGRAMS/EVENTS	19.92
		Department 699 - OTHER GENERAL GOVERNMENT Total:	19.92
		Fund 001 - GENERAL Total:	19.92
		Vendor 00490 - FAREWAY STORES INC Total:	19.92
Vendor: 00501 - FEHR GRAHAM & ASSOCIATES LLC			
Fund: 324 - STREET PROJECTS			
Department: 210 - STREETS			
FEHR GRAHAM & ASSOCIATES...	ENGINEERING FEES	ANDERSON STREET PROJECT	2,606.10
		Department 210 - STREETS Total:	2,606.10
		Fund 324 - STREET PROJECTS Total:	2,606.10
		Fund: 602 - WATER CAPITAL IMPROVEMENTS	
		Department: 810 - WATER	
FEHR GRAHAM & ASSOCIATES...	ENGINEERING FEES	BOOSTER PUMP REPLACEME...	2,999.25
		Department 810 - WATER Total:	2,999.25
		Fund 602 - WATER CAPITAL IMPROVEMENTS Total:	2,999.25
		Vendor 00501 - FEHR GRAHAM & ASSOCIATES LLC Total:	5,605.35
Vendor: 00549 - GENERAL TRAFFIC CONTROL INC			
Fund: 110 - ROAD USE TAX			
Department: 240 - TRAFFIC CONTROL/SAFETY			
GENERAL TRAFFIC CONTROL I...	LED GREEN BULBS	EQUIP REPAIR/MAINT	295.00
		Department 240 - TRAFFIC CONTROL/SAFETY Total:	295.00
		Fund 110 - ROAD USE TAX Total:	295.00
		Vendor 00549 - GENERAL TRAFFIC CONTROL INC Total:	295.00
Vendor: 00690 - INGRAM LIBRARY SERVICES INC			
Fund: 001 - GENERAL			
Department: 410 - LIBRARY			
INGRAM LIBRARY SERVICES INC	LIB BOOKS	LIBRARY MATERIALS	12.76

Expense Approval Report

Payment Dates: 3/6/2026 - 3/19/2026

Vendor Name	Description (Payable)	Account Name	Amount
INGRAM LIBRARY SERVICES INC	LIB BOOK ORDER	LIBRARY MATERIALS	35.68
		Department 410 - LIBRARY Total:	48.44
		Fund 001 - GENERAL Total:	48.44
Fund: 171 - LIBRARY GIFT & TRUST			
Department: 410 - LIBRARY			
INGRAM LIBRARY SERVICES INC	LIB BOOKS	LIBRARY MATERIALS	49.80
INGRAM LIBRARY SERVICES INC	LIB BOOKS	LIBRARY MATERIALS	21.00
		Department 410 - LIBRARY Total:	70.80
		Fund 171 - LIBRARY GIFT & TRUST Total:	70.80
		Vendor 00690 - INGRAM LIBRARY SERVICES INC Total:	119.24
Vendor: 02052 - JACK KLAUS			
Fund: 001 - GENERAL			
Department: 430 - PARKS & RECREATION			
JACK KLAUS	SEIBERT & SHELTER REIMB	REFUNDS/MISC	105.00
		Department 430 - PARKS & RECREATION Total:	105.00
		Fund 001 - GENERAL Total:	105.00
		Vendor 02052 - JACK KLAUS Total:	105.00
Vendor: 01901 - JASMINE WHITE			
Fund: 001 - GENERAL			
Department: 280 - AIRPORT			
JASMINE WHITE	AIRPORT MAINTENANCE	BUILDING/GROUNDS	40.00
JASMINE WHITE	AIRPORT MAINTENANCE	BUILDING/GROUNDS	40.00
		Department 280 - AIRPORT Total:	80.00
		Fund 001 - GENERAL Total:	80.00
		Vendor 01901 - JASMINE WHITE Total:	80.00
Vendor: 02053 - JEFF BREMER			
Fund: 001 - GENERAL			
Department: 410 - LIBRARY			
JEFF BREMER	LIB PROGRAM	PROGRAMS/EVENTS	200.00
		Department 410 - LIBRARY Total:	200.00
		Fund 001 - GENERAL Total:	200.00
		Vendor 02053 - JEFF BREMER Total:	200.00
Vendor: 00771 - JOHN KEPPLER			
Fund: 001 - GENERAL			
Department: 430 - PARKS & RECREATION			
JOHN KEPPLER	TREE & STUMP REMOVAL	PLANTS/SHRUBS/TREES	2,200.00
		Department 430 - PARKS & RECREATION Total:	2,200.00
Department: 510 - COMMUNITY BEAUTIFICATION			
JOHN KEPPLER	TREE & STUMP REMOVAL	TREE REMOVALS/CHIPPING F...	15,850.00
		Department 510 - COMMUNITY BEAUTIFICATION Total:	15,850.00
		Fund 001 - GENERAL Total:	18,050.00
		Vendor 00771 - JOHN KEPPLER Total:	18,050.00
Vendor: 00757 - KILBURG EQUIPMENT LLC			
Fund: 610 - SEWER			
Department: 815 - SEWER			
KILBURG EQUIPMENT LLC	JET VAC DOOR SEAL	VEHICLE REPAIR/MAINT	428.74
		Department 815 - SEWER Total:	428.74
		Fund 610 - SEWER Total:	428.74
		Vendor 00757 - KILBURG EQUIPMENT LLC Total:	428.74

Expense Approval Report

Payment Dates: 3/6/2026 - 3/19/2026

Vendor Name	Description (Payable)	Account Name	Amount
Vendor: 00830 - KMCH INC/DEL CO BROADCASTING INC			
Fund: 001 - GENERAL			
Department: 470 - SPECIAL EVENTS			
KMCH INC/DEL CO BROADCASTAS...	RADIO ANNOUNCEMENTS	PUBLIC RELATIONS/PUBLICAT...	468.00
		Department 470 - SPECIAL EVENTS Total:	468.00
		Fund 001 - GENERAL Total:	468.00
		Vendor 00830 - KMCH INC/DEL CO BROADCASTING INC Total:	468.00
Vendor: 00875 - LIBRARY IDEAS LLC			
Fund: 001 - GENERAL			
Department: 410 - LIBRARY			
LIBRARY IDEAS LLC	VOX BOOK ORDER	LIBRARY MATERIALS	444.24
		Department 410 - LIBRARY Total:	444.24
		Fund 001 - GENERAL Total:	444.24
		Vendor 00875 - LIBRARY IDEAS LLC Total:	444.24
Vendor: 00940 - MANCHESTER POLICE DEPT			
Fund: 168 - PARK GIFT & TRUST			
Department: 430 - PARKS & RECREATION			
MANCHESTER POLICE DEPT	2025 HERO HUSTLE RACE PRO...	HERO HUSTLE EXPENSES	4,500.00
		Department 430 - PARKS & RECREATION Total:	4,500.00
		Fund 168 - PARK GIFT & TRUST Total:	4,500.00
		Vendor 00940 - MANCHESTER POLICE DEPT Total:	4,500.00
Vendor: 00986 - MEDIACOM INC			
Fund: 001 - GENERAL			
Department: 110 - POLICE			
MEDIACOM INC	PHONE/INTERNET	TELEPHONE/INTERNET	30.59
		Department 110 - POLICE Total:	30.59
Department: 620 - CITY ADMINISTRATION			
MEDIACOM INC	PHONE/INTERNET	TELEPHONE/INTERNET	56.08
		Department 620 - CITY ADMINISTRATION Total:	56.08
		Fund 001 - GENERAL Total:	86.67
Fund: 110 - ROAD USE TAX			
Department: 210 - STREETS			
MEDIACOM INC	PHONE/INTERNET	TELEPHONE/INTERNET	56.07
		Department 210 - STREETS Total:	56.07
		Fund 110 - ROAD USE TAX Total:	56.07
Fund: 600 - WATER			
Department: 810 - WATER			
MEDIACOM INC	PHONE/INTERNET	TELEPHONE/INTERNET	56.08
		Department 810 - WATER Total:	56.08
		Fund 600 - WATER Total:	56.08
Fund: 610 - SEWER			
Department: 815 - SEWER			
MEDIACOM INC	PHONE/INTERNET	TELEPHONE/INTERNET	56.08
		Department 815 - SEWER Total:	56.08
		Fund 610 - SEWER Total:	56.08
		Vendor 00986 - MEDIACOM INC Total:	254.90
Vendor: 00988 - MEDICAL ASSOCIATES CLINIC			
Fund: 001 - GENERAL			
Department: 530 - BUILDING/HOUSING			
MEDICAL ASSOCIATES CLINIC	DRUG SCREENING	MINOR MEDICAL/PHYSICALS	64.00
		Department 530 - BUILDING/HOUSING Total:	64.00
		Fund 001 - GENERAL Total:	64.00

Expense Approval Report

Payment Dates: 3/6/2026 - 3/19/2026

Vendor Name	Description (Payable)	Account Name	Amount
Fund: 600 - WATER Department: 810 - WATER MEDICAL ASSOCIATES CLINIC	DRUG SCREENING	MINOR MEDICAL/PHYSICALS	30.00
		Department 810 - WATER Total:	30.00
		Fund 600 - WATER Total:	30.00
		Vendor 00988 - MEDICAL ASSOCIATES CLINIC Total:	94.00
Vendor: 01045 - MORTON SALT INC Fund: 110 - ROAD USE TAX Department: 250 - SNOW REMOVAL MORTON SALT INC	STREET SALT	STREET MAINT SUPPLIES (SALT)	3,153.20
		Department 250 - SNOW REMOVAL Total:	3,153.20
		Fund 110 - ROAD USE TAX Total:	3,153.20
		Vendor 01045 - MORTON SALT INC Total:	3,153.20
Vendor: 01083 - NEI3A Fund: 171 - LIBRARY GIFT & TRUST Department: 410 - LIBRARY NEI3A	LIB PROGRAM	EDUCATIONAL PROGRAMS	150.00
		Department 410 - LIBRARY Total:	150.00
		Fund 171 - LIBRARY GIFT & TRUST Total:	150.00
		Vendor 01083 - NEI3A Total:	150.00
Vendor: 01118 - OUR IOWA MAGAZINE Fund: 003 - HOTEL/MOTEL TAX Department: 499 - OTHER CULTURE/RECREATION OUR IOWA MAGAZINE	TOURISM AD: WHITEWATER ...	TOURISM/MARKETING	871.00
		Department 499 - OTHER CULTURE/RECREATION Total:	871.00
		Fund 003 - HOTEL/MOTEL TAX Total:	871.00
		Vendor 01118 - OUR IOWA MAGAZINE Total:	871.00
Vendor: 01120 - OVERDRIVE Fund: 001 - GENERAL Department: 410 - LIBRARY OVERDRIVE	AUDIO/EBOOKS	LIBRARY MATERIALS	795.97
		Department 410 - LIBRARY Total:	795.97
		Fund 001 - GENERAL Total:	795.97
		Vendor 01120 - OVERDRIVE Total:	795.97
Vendor: 01148 - PHILIPPSON CONCRETE INC Fund: 110 - ROAD USE TAX Department: 250 - SNOW REMOVAL PHILIPPSON CONCRETE INC	SNOW HAULING	EQUIP RENTAL	156.25
		Department 250 - SNOW REMOVAL Total:	156.25
		Fund 110 - ROAD USE TAX Total:	156.25
		Vendor 01148 - PHILIPPSON CONCRETE INC Total:	156.25
Vendor: 01158 - PITNEY BOWES Fund: 001 - GENERAL Department: 620 - CITY ADMINISTRATION PITNEY BOWES	POSTABE LABEL MAKER	POSTAGE	100.00
		Department 620 - CITY ADMINISTRATION Total:	100.00
		Fund 001 - GENERAL Total:	100.00
		Vendor 01158 - PITNEY BOWES Total:	100.00

Expense Approval Report

Payment Dates: 3/6/2026 - 3/19/2026

Vendor Name	Description (Payable)	Account Name	Amount
Vendor: 01161 - PIZZA RANCH			
Fund: 001 - GENERAL			
Department: 430 - PARKS & RECREATION			
PIZZA RANCH	MEETING	TRAINING/TRAVEL	60.97
		Department 430 - PARKS & RECREATION Total:	60.97
		Fund 001 - GENERAL Total:	60.97
		Vendor 01161 - PIZZA RANCH Total:	60.97
Vendor: 01627 - QUADIENT			
Fund: 001 - GENERAL			
Department: 290 - SOLID WASTE			
QUADIENT	COPY SYSTEMS.FOLDER/STUF...	IT/COMPUTER SERVICES	692.59
		Department 290 - SOLID WASTE Total:	692.59
Department: 510 - COMMUNITY BEAUTIFICATION			
QUADIENT	COPY SYSTEMS.FOLDER/STUF...	IT/COMPUTER SERVICES	692.59
		Department 510 - COMMUNITY BEAUTIFICATION Total:	692.59
		Fund 001 - GENERAL Total:	1,385.18
Fund: 600 - WATER			
Department: 810 - WATER			
QUADIENT	COPY SYSTEMS.FOLDER/STUF...	IT/COMPUTER SERVICES	692.59
		Department 810 - WATER Total:	692.59
		Fund 600 - WATER Total:	692.59
Fund: 610 - SEWER			
Department: 815 - SEWER			
QUADIENT	COPY SYSTEMS.FOLDER/STUF...	IT/COMPUTER SERVICES	692.59
		Department 815 - SEWER Total:	692.59
		Fund 610 - SEWER Total:	692.59
		Vendor 01627 - QUADIENT Total:	2,770.36
Vendor: 01240 - RICHARD BRUNSMANN			
Fund: 001 - GENERAL			
Department: 699 - OTHER GENERAL GOVERNMENT			
RICHARD BRUNSMANN	CIG PERMIT REFUND CORK N ...	REFUNDS/MISC	18.75
		Department 699 - OTHER GENERAL GOVERNMENT Total:	18.75
		Fund 001 - GENERAL Total:	18.75
		Vendor 01240 - RICHARD BRUNSMANN Total:	18.75
Vendor: 01977 - SCHMITZ PROPERTIES, LLC			
Fund: 302 - DOWNTOWN/COMMERCIAL INCENTIVE			
Department: 520 - ECONOMIC DEVELOPMENT			
SCHMITZ PROPERTIES, LLC	DOWNTOWN INCENTIVE FAC...	DOWNTOWN IMPROVEMENTS	22,500.00
		Department 520 - ECONOMIC DEVELOPMENT Total:	22,500.00
		Fund 302 - DOWNTOWN/COMMERCIAL INCENTIVE Total:	22,500.00
		Vendor 01977 - SCHMITZ PROPERTIES, LLC Total:	22,500.00
Vendor: 01313 - SCHUMACHER ELEVATOR INC			
Fund: 001 - GENERAL			
Department: 410 - LIBRARY			
SCHUMACHER ELEVATOR INC	ELEVATOR MAINTENANCE	EQUIP REPAIR/MAINT	202.26
		Department 410 - LIBRARY Total:	202.26
		Fund 001 - GENERAL Total:	202.26
		Vendor 01313 - SCHUMACHER ELEVATOR INC Total:	202.26

Expense Approval Report

Payment Dates: 3/6/2026 - 3/19/2026

Vendor Name	Description (Payable)	Account Name	Amount
Vendor: 01834 - SIMMONS PERRINE MOYER BERGMAN PLC			
Fund: 001 - GENERAL			
Department: 110 - POLICE			
SIMMONS PERRINE MOYER B...	LEGAL FEES	PROFESSIONAL/LEGAL FEES	2,796.50
		Department 110 - POLICE Total:	2,796.50
		Fund 001 - GENERAL Total:	2,796.50
		Vendor 01834 - SIMMONS PERRINE MOYER BERGMAN PLC Total:	2,796.50
Vendor: 01807 - STATE CHEMICAL SOLUTIONS			
Fund: 001 - GENERAL			
Department: 430 - PARKS & RECREATION			
STATE CHEMICAL SOLUTIONS	DUMPSTER MAGIC	BUILDING/GROUNDS	265.19
		Department 430 - PARKS & RECREATION Total:	265.19
		Fund 001 - GENERAL Total:	265.19
Fund: 610 - SEWER			
Department: 815 - SEWER			
STATE CHEMICAL SOLUTIONS	LIFT STATION MAINTENANCE	OPERATING SUPPLIES	346.80
		Department 815 - SEWER Total:	346.80
		Fund 610 - SEWER Total:	346.80
		Vendor 01807 - STATE CHEMICAL SOLUTIONS Total:	611.99
Vendor: 01422 - THE BREAD BASKET LLC			
Fund: 001 - GENERAL			
Department: 699 - OTHER GENERAL GOVERNMENT			
THE BREAD BASKET LLC	OPEN HOUSE SUPPLIES	PROGRAMS/EVENTS	457.00
		Department 699 - OTHER GENERAL GOVERNMENT Total:	457.00
		Fund 001 - GENERAL Total:	457.00
		Vendor 01422 - THE BREAD BASKET LLC Total:	457.00
Vendor: 02056 - THEIA MANAGEMENT CONSULTING LLC			
Fund: 001 - GENERAL			
Department: 620 - CITY ADMINISTRATION			
THEIA MANAGEMENT CONSU...	CITY MANAGER SEARCH	PROFESSIONAL/LEGAL FEES	18,118.02
		Department 620 - CITY ADMINISTRATION Total:	18,118.02
		Fund 001 - GENERAL Total:	18,118.02
		Vendor 02056 - THEIA MANAGEMENT CONSULTING LLC Total:	18,118.02
Vendor: 01482 - UNITY POINT CLINIC			
Fund: 001 - GENERAL			
Department: 530 - BUILDING/HOUSING			
UNITY POINT CLINIC	RANDOM DRUG/ALCOHOL SC...	MINOR MEDICAL/PHYSICALS	42.00
		Department 530 - BUILDING/HOUSING Total:	42.00
		Fund 001 - GENERAL Total:	42.00
Fund: 600 - WATER			
Department: 810 - WATER			
UNITY POINT CLINIC	RANDOM DRUG/ALCOHOL SC...	MINOR MEDICAL/PHYSICALS	42.00
		Department 810 - WATER Total:	42.00
		Fund 600 - WATER Total:	42.00
		Vendor 01482 - UNITY POINT CLINIC Total:	84.00
Vendor: 01493 - US CELLULAR			
Fund: 001 - GENERAL			
Department: 150 - FIRE			
US CELLULAR	FD CELL DATA	TELEPHONE/INTERNET	44.78
		Department 150 - FIRE Total:	44.78
		Fund 001 - GENERAL Total:	44.78
		Vendor 01493 - US CELLULAR Total:	44.78

Expense Approval Report

Payment Dates: 3/6/2026 - 3/19/2026

Vendor Name	Description (Payable)	Account Name	Amount
Vendor: 01496 - USA BLUE BOOK			
Fund: 600 - WATER			
Department: 810 - WATER			
USA BLUE BOOK	METER SUPPLIES	METER PURCHASE	102.79
		Department 810 - WATER Total:	102.79
		Fund 600 - WATER Total:	102.79
Fund: 610 - SEWER			
Department: 815 - SEWER			
USA BLUE BOOK	LAB SUPPLIES	TESTING	725.94
USA BLUE BOOK	LAB TOWELS	TESTING	57.56
USA BLUE BOOK	METER SUPPLIES	METER PURCHASE	102.80
		Department 815 - SEWER Total:	886.30
		Fund 610 - SEWER Total:	886.30
		Vendor 01496 - USA BLUE BOOK Total:	989.09
Vendor: 01520 - WALMART			
Fund: 001 - GENERAL			
Department: 410 - LIBRARY			
WALMART	LIB PROGRAM	PROGRAMS/EVENTS	91.99
WALMART	LIB PROGRAM	OFFICE SUPPLIES	35.80
		Department 410 - LIBRARY Total:	127.79
		Fund 001 - GENERAL Total:	127.79
		Vendor 01520 - WALMART Total:	127.79
Vendor: 01564 - WINDSTREAM			
Fund: 001 - GENERAL			
Department: 110 - POLICE			
WINDSTREAM	DYNAMIC IP/SIP TRUNKS	TELEPHONE/INTERNET	150.31
		Department 110 - POLICE Total:	150.31
Department: 430 - PARKS & RECREATION			
WINDSTREAM	DYNAMIC IP/SIP TRUNKS	TELEPHONE/INTERNET	69.38
		Department 430 - PARKS & RECREATION Total:	69.38
Department: 530 - BUILDING/HOUSING			
WINDSTREAM	DYNAMIC IP/SIP TRUNKS	TELEPHONE/INTERNET	69.38
		Department 530 - BUILDING/HOUSING Total:	69.38
Department: 620 - CITY ADMINISTRATION			
WINDSTREAM	DYNAMIC IP/SIP TRUNKS	TELEPHONE/INTERNET	150.32
		Department 620 - CITY ADMINISTRATION Total:	150.32
		Fund 001 - GENERAL Total:	439.39
Fund: 600 - WATER			
Department: 810 - WATER			
WINDSTREAM	DYNAMIC IP/SIP TRUNKS	TELEPHONE/INTERNET	69.38
		Department 810 - WATER Total:	69.38
		Fund 600 - WATER Total:	69.38
Fund: 610 - SEWER			
Department: 815 - SEWER			
WINDSTREAM	DYNAMIC IP/SIP TRUNKS	TELEPHONE/INTERNET	69.38
		Department 815 - SEWER Total:	69.38
		Fund 610 - SEWER Total:	69.38
		Vendor 01564 - WINDSTREAM Total:	578.15
Vendor: 01567 - WOODWARD COMMUNICATIONS INC			
Fund: 001 - GENERAL			
Department: 110 - POLICE			
WOODWARD COMMUNICATI...	SUBSCRIPTION	DUES/SUBSCRIPTIONS	35.00
		Department 110 - POLICE Total:	35.00

Expense Approval Report

Payment Dates: 3/6/2026 - 3/19/2026

Vendor Name	Description (Payable)	Account Name	Amount
Department: 620 - CITY ADMINISTRATION			
WOODWARD COMMUNICATI...	SUBSCRIPTION	DUES/SUBSCRIPTIONS	35.00
WOODWARD COMMUNICATI...	PUBLICATION EXPENSE	PRINTING/PUBLICATION	539.28
Department 620 - CITY ADMINISTRATION Total:			574.28
Fund 001 - GENERAL Total:			609.28
Vendor 01567 - WOODWARD COMMUNICATIONS INC Total:			609.28
Grand Total:			124,376.32

Report Summary

Fund Summary

Fund	Expense Amount	Payment Amount
001 - GENERAL	54,972.65	54,972.65
003 - HOTEL/MOTEL TAX	871.00	871.00
110 - ROAD USE TAX	4,194.66	4,194.66
112 - EMPLOYEE BENEFITS	164.67	164.67
168 - PARK GIFT & TRUST	10,000.00	10,000.00
171 - LIBRARY GIFT & TRUST	558.71	558.71
180 - POLICE CANINE	-54.99	-54.99
302 - DOWNTOWN/COMMERCIAL INCENTIVE	22,500.00	22,500.00
324 - STREET PROJECTS	12,606.10	12,606.10
600 - WATER	2,693.94	2,693.94
602 - WATER CAPITAL IMPROVEMENTS	2,999.25	2,999.25
610 - SEWER	12,870.33	12,870.33
Grand Total:	124,376.32	124,376.32

Account Summary

Account Number	Account Name	Expense Amount	Payment Amount
001-110-62100	DUES/SUBSCRIPTIONS	35.00	35.00
001-110-63710	ELECTRICITY	227.81	227.81
001-110-63730	TELEPHONE/INTERNET	180.90	180.90
001-110-64110	PROFESSIONAL/LEGAL F...	2,796.50	2,796.50
001-130-63710	ELECTRICITY	20.00	20.00
001-150-63710	ELECTRICITY	87.92	87.92
001-150-63730	TELEPHONE/INTERNET	44.78	44.78
001-230-63710	STREET LIGHTING ELECT...	7,833.37	7,833.37
001-280-63100	BUILDING/GROUNDS	80.00	80.00
001-280-63710	ELECTRICITY	288.35	288.35
001-290-64190	IT/COMPUTER SERVICES	692.59	692.59
001-410-62300	TRAINING/TRAVEL	52.50	52.50
001-410-63500	EQUIP REPAIR/MAINT	202.26	202.26
001-410-64990	PROGRAMS/EVENTS	315.87	315.87
001-410-65020	LIBRARY MATERIALS	1,921.67	1,921.67
001-410-65060	OFFICE SUPPLIES	35.80	35.80
001-430-62300	TRAINING/TRAVEL	60.97	60.97
001-430-63100	BUILDING/GROUNDS	517.39	517.39
001-430-63710	ELECTRICITY	201.04	201.04
001-430-63730	TELEPHONE/INTERNET	69.38	69.38
001-430-64970	REFUNDS/MISC	105.00	105.00
001-430-65600	PLANTS/SHRUBS/TREES	2,200.00	2,200.00
001-470-64140	PUBLIC RELATIONS/PUBL...	468.00	468.00
001-510-63990	TREE REMOVALS/CHIPPI...	15,850.00	15,850.00
001-510-64190	IT/COMPUTER SERVICES	692.59	692.59
001-530-61830	MINOR MEDICAL/PHYSI...	106.00	106.00
001-530-63730	TELEPHONE/INTERNET	69.38	69.38
001-620-62100	DUES/SUBSCRIPTIONS	35.00	35.00
001-620-63710	ELECTRICITY	323.21	323.21
001-620-63730	TELEPHONE/INTERNET	206.40	206.40
001-620-64110	PROFESSIONAL/LEGAL F...	18,118.02	18,118.02
001-620-64140	PRINTING/PUBLICATION	539.28	539.28
001-620-65080	POSTAGE	100.00	100.00
001-699-64970	REFUNDS/MISC	18.75	18.75
001-699-64990	PROGRAMS/EVENTS	476.92	476.92
003-499-64900	TOURISM/MARKETING	871.00	871.00
110-210-63710	ELECTRICITY	477.32	477.32
110-210-63730	TELEPHONE/INTERNET	56.07	56.07
110-210-65060	OFFICE SUPPLIES	56.82	56.82
110-240-63500	EQUIP REPAIR/MAINT	295.00	295.00
110-250-64150	EQUIP RENTAL	156.25	156.25

Account Summary

Account Number	Account Name	Expense Amount	Payment Amount
110-250-64170	STREET MAINT SUPPLIES ..	3,153.20	3,153.20
112-699-64970	REFUNDS/MISC	164.67	164.67
168-430-65700	HERO HUSTLE EXPENSES	10,000.00	10,000.00
171-410-64900	EDUCATIONAL PROGRA...	150.00	150.00
171-410-65020	LIBRARY MATERIALS	408.71	408.71
180-110-65070	OPERATING SUPPLIES	-54.99	-54.99
302-520-67900	DOWNTOWN IMPROVE...	22,500.00	22,500.00
324-210-64110	PROFESSIONAL/LEGAL F...	10,000.00	10,000.00
324-210-67715	ANDERSON STREET PRO...	2,606.10	2,606.10
600-810-61830	MINOR MEDICAL/PHYSI...	72.00	72.00
600-810-63710	ELECTRICITY	1,701.10	1,701.10
600-810-63730	TELEPHONE/INTERNET	125.46	125.46
600-810-64190	IT/COMPUTER SERVICES	692.59	692.59
600-810-67240	METER PURCHASE	102.79	102.79
602-810-67750	BOOSTER PUMP REPLAC...	2,999.25	2,999.25
610-815-63100	BUILDING/GROUNDS	97.00	97.00
610-815-63200	SEWER MAINT/REPAIR	38.97	38.97
610-815-63320	VEHICLE REPAIR/MAINT	428.74	428.74
610-815-63500	EQUIP REPAIR/MAINT	267.08	267.08
610-815-63710	ELECTRICITY	6,909.16	6,909.16
610-815-63730	TELEPHONE/INTERNET	125.46	125.46
610-815-64190	IT/COMPUTER SERVICES	692.59	692.59
610-815-64210	TESTING	783.50	783.50
610-815-65040	MINOR EQUIPMENT	29.74	29.74
610-815-65070	OPERATING SUPPLIES	3,395.29	3,395.29
610-815-67240	METER PURCHASE	102.80	102.80
Grand Total:		124,376.32	124,376.32

Project Account Summary

Project Account Key	Expense Amount	Payment Amount
None	124,376.32	124,376.32
Grand Total:	124,376.32	124,376.32

Minutes
Regular Meeting of the City of Manchester Parks and Recreation Commission
Tuesday, March 17, 2026 **City Hall** **5:00 pm**

Present: Annette Lenz, Mike Wessels, Nick La Rosa, Tim Egemo

Absent: Melissa Coates

Guests:

Also Present: Doug Foley, Director of Parks and Recreation

Consent agenda:

- a. Approval of the minutes of last month’s regular meeting of the City of Manchester Parks and Recreation Commission.
- b. Approval of the bills.

It was motioned by Commissioner Lenz and seconded by Commissioner Coates to approve the consent agenda. Motion carried, all ayes.

VENDOR	DESCRIPTION	AMOUNT
ACCESS SYSTEMS LEASING	COPIER/NETWORK MAINT AGREEMENT	28.95
ALLIANT ENERGY	ELECTRICITY	1,063.69
BLACK HILLS ENERGY	NATURAL GAS	291.15
DOUG FOLEY	IPRA FOUNDATION MEETING	72.50
FAREWAY STORES	SEIBERT SUPPLIES	15.98
IOWA PARK & REC ASSOCIATION	SPRING CONFERENCE	275.00
JOHN DEERE FINANCIAL	SUPPLIES	17.99
PALMER HARDWARE	SUPPLIES	103.19
THREE RIVERS FS	VEHICLE FUEL	160.41
WINDSTREAM	TELEPHONE/INTERNET	69.38
	TOTAL	2,098.24

Recreation Business

Recreation Programs:

The following programs on currently ongoing: *Adult Coed Volleyball and Men’s basketball League are nearing the end of their respective seasons.

Recently Finished Programs: 1st Lifeguard Class

Upcoming Programs: Lifeguard Class and WSI classes.

Park Business

Foley reported the following:

* The Baum Park shelter and restroom renovation project low bid was from Loecke Building Services for \$143,750. The total cost is estimated at \$169,850 when including a 10% contingency and architecture costs. The bid was approved by City Council, and the project will tentatively begin in late July and should be completed by the end of summer.

*The low bid to replace the John Deere tractor that serves as our primary snow removal and secondary mower was from Bodensteiner Implement. City Council approved the purchase for \$38,900. The tractor will include a new mower deck, snow blower, broom and bucket. Once it arrives, the old tractor will be put out for sealed bid.

*The Grand Ave trail project bid came in at \$190,000 which was approximately \$50,000 less than the engineer’s estimate. The project will begin this Spring.

Aquatic Center

*The tentative opening day has been set for the Memorial Day weekend/Saturday, May 23rd. This is the earliest the pool will open due to an early Memorial Day holiday.

Other Business

*Vandalism report: nothing to report.

*Potential Dog Park lights: The lights have been installed.

*Foley and La Rosa discussed the Disc Golf signage. Foley hopes to have signs in place within a month.

Adjourn: Meeting adjourned at 5:23 p.m.

Doug Foley, Director of Parks and Recreation

Manchester Public Library Board Minutes

February 12, 2026

The meeting was called to order by Vice President, Allison Hemann at 7:30 am.

Present:

Lucas Elsbernd, Janet Giannini, Anita Palmer, Ben Engelken, Tadd Moorman, Nathan Lamb, Millie Kehrli, Allison Hemann, Alison Hegland-Library Director

Approval of Agenda:

Lucas Elsbernd made a motion to approve the agenda as presented, Janet Giannini seconded. There was no further discussion, motion carried.

Approval of Minutes:

Minutes of the January 8, 2026, meeting were presented. Lucas Elsbernd made a motion to approve, Millie Kehrli seconded. There was no further discussion, motion carried.

Approval of Bills:

Alison Hegland presented bills. Lucas Elsbernd made a motion to approve the bills as presented, Janet Giannini seconded. There was no further discussion, motion carried.

Community Input:

N/A

Administrators Report:

a. Programs, statistics, and donations:

- The library had 7156 physical and online materials checked out in January. Of this, 2,028 were digital. 123 were from the Delaware County Library Association.
- The library had 3,350 visits in January. There were 14 class visits with 275 attending, 1 teen advisory board meeting with 10 attending, 2 children's programs with 9 attending, 1 passive children's scavenger hunt with 141 attending, 1 passive children's programs with 151 attending, 1 teen event with 5 attending, 4 adult programs with 61 attending, and 1 general interest program with 14 attending.
- The meeting room was used 9 times with 57 attending.
- There were 4 notary sessions, 2 tech time sessions with 2 attending, 4 Thursday Morning Coffee Club events with 47 attending, 2 book club events with 16 attending, and 6 book bundles were curated.
- Computers had 267 uses, children's iPads had 7 uses, and hotspot checkouts had 7 uses.
- Public Wi-Fi was used 675 times by 218 devices
- 14 new library cards issued

Other items that Alison shared:

- The friends bar crawl fundraiser will be held on Thursday, February 12. There will be stations setup around the library with different bars available for purchase, and they will feature books at each of the stations.
- The cyber safety event hosted by the Manchester Police Department had 45 people in attendance on January 22nd. KCRG was in attendance and recorded the meeting to use portions to create a segment. This was the second event and has been a good way to share cyber safety information with parents and community members.

- Alison has been working with All Secure to update some security points and smoke detectors. The current points are aged out and will be replaced with newer technology as they fail. There are currently two points that need replaced.
- Alison shared updates on the Community Foundation funds. There are two funds with the foundation. One is an agency fund, the other is a donor fund where funds from donations, Great Give Day, and other donation sources are deposited. The agency fund grew from \$30,158.50 to \$32,822.86 in 2025. The library can take a grant of up to 5% from that account every year, which was \$1,330 this year. The donor fund grew from \$22,161.51 to \$32,570 in 2025. The library received a grant of \$620 from this fund. \$8,000.73 in donations was received in 2025, between donations from the Great Give Day of around \$1,400 and other donations of around \$6,575. Once the approved grant amounts are determined, Alison will let the board know what they would like to spend the grant funds on for the board to approve. The grant doesn't have to be taken, but is helpful to fund special projects.
- There are several bills being presented at the state level that impact libraries. The ILA believes there are a couple of bills that will make it through the first funnel and will get approved by the committee and sub-committee. Most of the bills are related to the censoring of library information for children, and also partnerships between public libraries and schools. It is unclear how the proposed bill would affect the partnership between the Manchester Public Library and St. Mary's School. It could also affect outreach events for the library and the area public schools. Alison will keep the board updated on the progress of these bills, and further discussion will be necessary if they pass.

b. Erate

- Alison has begun the Erate process because the library is looking for bids to change internet providers. She is looking into what it would take to get ICN installed in the library again, as it had previously been removed from the building. ICN is not necessarily the cheapest option, but tends to be a more reliable internet provider that has fewer outages than other providers. The library will be switching from the current provider due to billing and outage issues. Alison will report back to the board after the bids come back in.

c. Discussion on closings

- The library adjusted its hours two days during the week of January 26 due to staff illness. The library was closed during the morning of Wednesday, January 28th, and the evening of Thursday, January 29th. Alison reviewed all staffing options before making the decision and adjusted hours to best serve patrons given the staffing shortage. One program had to be moved.

Old Business:

a. Cindy's certification update

- Alison is proposing to have Cindy complete the children's services certification and not require her to complete a full certification in order to receive a \$.25 raise upon completion. Cindy will be completing her MA in library science in December 2026, so she will not need to complete the full certification. If there would be an issue with her completing her MA, she would then need to go back and complete the full certification. Alison expects Cindy to be able to complete the children's services portion within the next couple of months. The board will vote to approve the raise upon completion of the children's services certification.

b. Carnegie Check

- The library received the \$10,000 check on February 2nd. The funds can be used on a single project or multiple projects to benefit the library and the community. Alison will make recommendations on how to utilize the funds on a building project or library materials.
- c. Small meeting room renovation
- Alison presented options for funding the renovation of the small meeting room. The Joyce Hansel Estate funds are an option. Funds from this estate were intended to be used for audiobooks. Alison stated that the \$42,000 that was donated is much greater than the amount they would spend on audiobooks and is proposing that some of the funds be used for the small meeting room renovation. Alison noted that Joyce used to spend a lot of time in that room when it was the genealogy room. The renovation would not use all of the funds from the estate, and the remaining funds could be used on audiobooks. If these funds are used, Alison proposes that a plaque would be hung by the door stating that the funds for the renovation were donated by the Joyce Hansel Estate. Alison also mentioned that the remaining funds could be used to either purchase more audiobook CDs or could be put toward increasing the subscriptions for audiobooks through Libby and other sources. The other option for the renovations would be the funds from the Kay Hovey Estate. Alison's recommendation is to use the Joyce Hansel Estate. A recommendation was made to reach out to the executors of the estate to get their thoughts on using the funds for the renovation.
 - Millie Kehrli made a motion to use the Joyce Hansel Estate to update the small meeting room and to use the remainder of the funds to purchase a mixture of physical and digital audiobooks. Anita Palmer seconded, motion carried.

New Business:

- a. Budget Proposal:
- Alison shared the proposed budget for next fiscal year. The line item for the Delaware County library tax is unknown because the county has not approved the increase for next fiscal year yet. In the past, it has typically been around a 3% increase. Most of the budget will remain the same from the past year, pending no major changes to the library building. Alison requested two changes to this year's budget. The first change was a \$500 increase to the line item for telephone and internet, which Alison has requested to change for next year's budget as well, due to the charges continuing to be higher than expected. This would put the budget for that line item at \$2,500 next year. The other change was to the printing and publication line item, which Alison asked to increase to \$400 from \$300 for this fiscal year, and has requested to increase the line item to \$400 for next fiscal year as well.
 - Alison discussed the capital improvement plan for the downstairs restroom to make it ADA-compliant. The project is estimated to cost \$40,000.00. Alison has applied for a grant to cover a portion of this project, which would cover \$10,000 or \$20,000 if it is awarded.
 - Alison discussed the capital improvement plan for the small meeting room, which is estimated at \$20,000 and would be completed using funds from the gift and trust.
 - Alison mentioned there are a couple of other capital improvement plans to be completed over the next couple of years which would likely be funded through gift and trust.
 - The budget will have a new line-item next year for the Kay Hovey Estate. Alison noted that those funds will be used at the library board's discretion. Alison also informed the city that the check was received from the Carnegie Corporation and that those funds will be used at the library board's discretion.

- Lucas Elsbernd made a motion to approve the proposed budget. Tadd Moorman seconded. There was no further discussion, motion carried.
- b. Security Cameras Quote
- Alison presented a quote for new security cameras from ITS. The quote includes a 2-camera multisensory setup that would be placed in the eaves on the front of the building. It also includes a dome camera for the rear of the building. ITS believes the quote is higher than the final bill should be but estimated high due to it being an older building. Alison shared some of the features that the new camera system would have. The system would be separate from the city's camera system. It is cloud-based, and the library would have access to the footage for 30 days and has the ability to archive footage if an incident were to occur. Alison and Angie would have access as well as potentially one other user. Alison is proposing to pay for the project with gift and trust. Discussion was had to ensure that having the cameras outside does not create any legal issues. Alison had reached out to the state, and they told her as long as the cameras are not inside the building, there are no issues.
 - Anita Palmer made a motion to use gift and trust toward the camera project. Janet Giannini seconded. There was no further discussion, motion carried.
- c. ITS Managed Services
- Alison obtained a quote from ITS for IT services. The quote came in higher than the current contract through Access Systems, and she has determined Access Systems is the best option at this time.
- d. Board Education – Director and Review and Amendments Policies
- Alison went over changes to Chapter 8 - The Director of the Library Policy. Changes were made to line item 10 to change it to overseeing training since the assistant director also helps to train. The other changes were to clarify procedures or change grammar.
 - Alison went over a change to Chapter 9 - The Review and Amendments Policy, which clarifies how often the board has to review policies in accordance with accreditation standards.
 - Lucas Elsbernd made a motion to approve the changes to the policies as presented. Nathan Lamb seconded. There was no further discussion, motion carried.

The meeting was adjourned at 8:28 am. Next meeting is March 12, 2026 at 7:30am.

Respectfully submitted,
Ben Engelken, Board Secretary

REGULAR MEETING OF THE MANCHESTER PLANNING AND ZONING COMMISSION

Wednesday, March 4, 2026

CITY COUNCIL CHAMBERS

8:00 a.m.

PRESENT: Autumn Domeyer, Ryan Hauser, Nancy Oehler, Dave Smith, JoAnn Swinton, Scott Wegmann

ABSENT: Stuart Sleper

GUESTS: Building Inspector Tim Heims, Randy Rattenborg

The regular meeting of the Manchester Planning and Zoning Commission was called to order by Chairperson Smith at 8:00 a.m.

MINUTES

No minutes were reviewed.

SHOVER’S HIGHWAY #20 SUBDIVISION

PRELIMINARY & FINAL PLATS

The commission reviewed the preliminary and final plat for Shover Highway 20 Subdivision on February 19, 2026. This plat was subsequently approved by City Council on February 23rd. Surveyor Randy Rattenborg explained the original plat consisted of 3 lots, but due to a financial issue, the developer would now like to subdivide the house and the buildings as well. Lot 1 will become Lots 1 & 2, Lot 2 will become Lot 3, and Lot 3 will become Lot 4. No other changes have been made to the plat.

**PLANNING AND ZONING COMMISSION
RESOLUTION APPROVING FINAL PLAT of SHOVER’S HIGHWAY #20 SUBDIVISION**

WHEREAS, the FINAL PLAT of **SHOVER’S HIGHWAY #20 SUBDIVISION**, A SUBDIVISION OF PART OF THE SOUTH 1/2 OF THE SW 1/4 OF SECTION 35, T89N, R5W OF THE FIFTH PRINCIPAL MERIDIAN, DELAWARE COUNTY, IOWA affecting premises more specifically described in the Surveyor’s Certificate of Randall L. Rattenborg, dated February 12, 2026, has been filed with the Planning and Zoning Commission of the City of Manchester, Delaware County, Iowa; and

WHEREAS, this approval is intended to replace and supersede any prior approvals of the subdivision plat for SHOVER’S HIGHWAY #20 SUBDIVISION previously recommended by the Planning & Zoning Commission; and

WHEREAS, the Commission has reviewed the FINAL PLAT of **SHOVER’S HIGHWAY #20 SUBDIVISION**, same being located within the two-mile jurisdiction of the City of Manchester, and finds that same should be recommended for approval.

NOW, THEREFORE, BE IT RESOLVED, that the FINAL PLAT of **SHOVER’S HIGHWAY #20 SUBDIVISION**, be, and the same is hereby acknowledged, approved and accepted, the Commission hereby recommending to the City Council that same be approved.

Adopted and passed this 4th day of March, 2026.

PLANNING & ZONING COMMISSION
CITY OF MANCHESTER, IOWA

By _____
David Smith, Chairperson

By _____
Laura Thomas, Recording Secretary

Motion:

Commissioner Domeyer motioned to recommend the City Council approve the preliminary and final plat as presented. The motion was seconded by Commissioner Oehler.

ON A CALL OF ROLL

AYES: Wegmann, Domeyer, Oehler, Hauser, Smith

NAYS: None

ADJOURN

Commissioner Wegmann motioned to adjourn the Planning and Zoning Commission meeting at 8:03 a.m. The motion was seconded by Commissioner Domeyer. AYES: All.

Laura K. Thomas, Recording Secretary

Permit # 2839001
 Facility Name: MANCHESTER CITY OF STP

Monthly Operation Report IOWA DEPARTMENT OF NATURAL RESOURCES NPDS - Operation Permit System INFLUENT Data

Outfall #: 001
 Month/Year: 2-2026

Mon. Point	RAW WASTE								
	FLOW	BOD5		TSS		TKN		TEMP	PH
Parameter	MGD	MG/L	LBS/DAY	MG/L	LBS/DAY	MG/L	LBS/DAY	FAHRENHEIT	STD UNITS
Units	7/WEEK OR DAILY	2 TIMES PER WEEK	2 TIMES PER WEEK	1 TIME PER WEEK	1 TIME PER WEEK	1 EVERY MONTH	1 EVERY MONTH	2 TIMES PER WEEK	2 TIMES PER WEEK
Frequency									
Start Date									
End Date	Permit Duration	Permit Duration	Permit Duration	Permit Duration	Permit Duration	Permit Duration	Permit Duration	Permit Duration	Permit Duration
No Discharge									
LOQ									
Day: 1	0.427								
2	0.452							50	7.9
3	0.442	211	777.80508	152	560.31456				
4	0.455					38.8	147.23436		
5	0.435	166	602.2314						
6	0.424							50	7.5
7	0.397								
8	0.426								
9	0.433							50	7.9
10	0.429	157	561.72402	160	572.4576				
11	0.417								
12	0.426	184	653.72256						
13	0.416							50	8.1
14	0.387								
15	0.394								
16	0.412							52	7.2
17	0.423	235	829.0377	196	691.45272				
18	0.428								
19	0.431	264	948.95856						
20	0.418							50	7.4
21	0.396								
22	0.422								
23	0.443							50	7.8
24	0.421	214	751.38396	368	1292.09952				
25	0.433								
26	0.42	179	627.0012						
27	0.425							50	8.3
28	0.4								
29									
30									
31									
Total	11.832	1610	5751.86448	876	3116.3244	38.8	147.23436	402	62.1
Monthly Avg.	0.422571429	201.25	718.98306	219	779.0811	38.8	147.23436	50.25	7.7625
Daily Max.	0.455	264	948.95856	368	1292.09952	38.8	147.23436	52	8.3
Daily Min.	0.387	157	561.72402	152	560.31456	38.8	147.23436	50	7.2
Max. 7/Avg.	0.433142857	249.5	888.99813	368	1292.09952	38.8	147.23436	51	8.05

Permit # 2839001
 Facility Name: MANCHESTER CITY OF STP

Monthly Operation Report IOWA DEPARTMENT OF NATURAL RESOURCES NPDS - Operation Permit System EFFLUENT Data

Outfall #: 001
 Month/Year: 2-2026

Mon. Point Parameter	EFFLUENT AFTER DISINFECTION								
	CBOD5		TSS		NH3-N		CR(T)		
Units	MG/L	LBS/DAY	MG/L	LBS/DAY	MG/L	LBS/DAY	MG/L	LBS/DAY	MG/L
Frequency	2 TIMES PER WEEK	2 TIMES PER WEEK	1 TIME PER WEEK	1 TIME PER WEEK	2 TIMES PER WEEK	2 TIMES PER WEEK	1 EVERY MONTH	1 EVERY MONTH	1 EVERY 3 MONTHS
Start Date									
End Date	Permit Duration	Permit Duration	Permit Duration	Permit Duration	Permit Duration	Permit Duration	Permit Duration	Permit Duration	Permit Duration
No Discharge							05 - NO DETECTION	05 - NO DETECTION	06 - NOT REQ / MP
LOQ									
Day: 1									
2							<0.00100	<	
3	3.9	14.376492	4	14.74512	0.0523	0.192792444			
4									
5	4	14.5116			0.0874	0.31707846			
6									
7									
8									
9									
10	3.9	13.953654	4.4	15.742584	0.0449	0.160645914			
11									
12	3	10.65852			0.0488	0.173378592			
13									
14									
15									
16									
17	3.6	12.700152	2.8	9.877896	0.0388	0.136879416			
18									
19	3.3	11.861982			0.07	0.2516178			
20									
21									
22									
23									
24	3.4	11.937876	3.2	11.235648	0.0718	0.252099852			
25									
26	4.1	14.36148			0.0389	0.13625892			
27									
28									
29									
30									
31									
Total	29.2	104.361756	14.4	51.601248	0.4529	1.620751398	0	0	
Monthly Avg.	3.65	13.0452195	3.6	12.900312	0.0566125	0.202593925	0	0	
Daily Max.	4.1	14.5116	4.4	15.742584	0.0874	0.31707846			
Daily Min.	3	10.65852	2.8	9.877896	0.0388	0.13625892			
Max. 7/Avg.	3.95	14.444046	4.4	15.742584	0.06985	0.254935452			

Permit #
 Facility Name:

Outfall #:
 Month/Year:

Mon. Point								EFFLUENT AFTER DISINFECTION - GEO MEAN
Parameter	T-N	PHOS		TEMP	CU		PH	E. COLI
Units	LBS/DAY	MG/L	LBS/DAY	FAHRENHEIT	MG/L	LBS/DAY	STD UNITS	#/100 ML
Frequency	1 EVERY 3 MONTHS	1 EVERY 3 MONTHS	1 EVERY 3 MONTHS	2 TIMES PER WEEK	1 EVERY MONTH	1 EVERY MONTH	2 TIMES PER WEEK	GEO. MEAN 1/3 MONTHS
Start Date								
End Date	Permit Duration	Permit Duration	Permit Duration	Permit Duration	Permit Duration	Permit Duration	Permit Duration	Permit Duration
No Discharge	06 - NOT REQ / MP	06 - NOT REQ / MP	06 - NOT REQ / MP					06 - NOT REQ / MP
LOQ								
Day: 1								
2				46	0.0162	0.061068816	7.2	
3								
4								
5								
6				48			7	
7								
8								
9				48			7	
10								
11								
12								
13				50			7	
14								
15								
16				52			7	
17								
18								
19								
20				50			7	
21								
22								
23				47			7	
24								
25								
26								
27				47			7	
28								
29								
30								
31								
Total	0		0	388	0.0162	0.061068816	56.2	
Monthly Avg.				48.5	0.0162	0.061068816	7.025	
Daily Max.				52	0.0162	0.061068816	7.2	
Daily Min.				46	0.0162	0.061068816	7	
Max. 7/Avg.				51	0.0162	0.061068816	7.1	

Permit # 2839001
 Facility Name: MANCHESTER CITY OF STP

Monthly Operation Report IOWA DEPARTMENT OF NATURAL RESOURCES NPDS - Operation Permit System EFFLUENT Data

SIU: Paladin Attachments
 Outfall #: 001
 Month/Year: 2-2026

Mon. Point	PRIOR TO DISCHARGE TO CITY									
	Parameter	FLOW	ZN		CD		CR(T)		CN(T)	
Units	MGD	MG/L	LBS/DAY	MG/L	LBS/DAY	MG/L	LBS/DAY	MG/L	LBS/DAY	MG/L
Frequency	1 EVERY BATCH	1 EVERY MONTH	1 EVERY MONTH	1 EVERY MONTH	1 EVERY MONTH	1 EVERY MONTH	1 EVERY MONTH	1 EVERY MONTH	1 EVERY MONTH	1 EVERY MONTH
Start Date										
End Date	Permit Duration	Permit Duration	Permit Duration	Permit Duration	Permit Duration	Permit Duration	Permit Duration	Permit Duration	Permit Duration	Permit Duration
No Discharge				05 - NO DETECTION	05 - NO DETECTION			05 - NO DETECTION	05 - NO DETECTION	
LOQ										
Day: 1										
2										
3										
4										
5										
6										
7										
8										
9										
10	0.00054	0.0731	0.000329213	<0.000200	<	0.00509	2.29233E-05	<0.0100	<	0.0254
11										
12										
13										
14										
15										
16										
17										
18										
19										
20										
21										
22										
23										
24										
25										
26										
27										
28										
29										
30										
31										
Total	0.00054	0.0731	0.000329213	0	0	0.00509	2.29233E-05	0	0	0.0254
Monthly Avg.	0.00054	0.0731	0.000329213	0	0	0.00509	2.29233E-05	0	0	0.0254
Daily Max.	0.00054	0.0731	0.000329213			0.00509	2.29233E-05			0.0254
Daily Min.	0.00054	0.0731	0.000329213			0.00509	2.29233E-05			0.0254
Max. 7/Avg.	0.00054	0.0731	0.000329213			0.00509	2.29233E-05			0.0254

Permit #
 Facility Name:

SIU:
 Outfall #:
 Month/Year:

Mon. Point	Y SEWER								
Parameter	II	AG		TTO	CU		PB		PH
Units	LBS/DAY	MG/L	LBS/DAY	MG/L	MG/L	LBS/DAY	MG/L	LBS/DAY	STD UNITS
Frequency	1 EVERY MONTH	1 EVERY MONTH	1 EVERY MONTH	1 EVERY MONTH	1 EVERY MONTH	1 EVERY MONTH	1 EVERY MONTH	1 EVERY MONTH	1 EVERY MONTH
Start Date									
End Date	Permit Duration	Permit Duration	Permit Duration	Permit Duration	Permit Duration	Permit Duration	Permit Duration	Permit Duration	Permit Duration
No Discharge		05 - NO DETECTION	05 - NO DETECTION	12 - CERTIFIED					
LOQ									
Day: 1									
2									
3									
4									
5									
6									
7									
8									
9									
10	0.000114391	<0.00100	<		0.189	0.00085118	0.00141	6.35008E-06	6.97
11									
12									
13									
14									
15									
16									
17									
18									
19									
20									
21									
22									
23									
24									
25									
26									
27									
28									
29									
30									
31									
Total	0.000114391	0	0		0.189	0.00085118	0.00141	6.35008E-06	6.97
Monthly Avg.	0.000114391	0	0		0.189	0.00085118	0.00141	6.35008E-06	6.97
Daily Max.	0.000114391				0.189	0.00085118	0.00141	6.35008E-06	6.97
Daily Min.	0.000114391				0.189	0.00085118	0.00141	6.35008E-06	6.97
Max. 7/Avg.	0.000114391				0.189	0.00085118	0.00141	6.35008E-06	6.97

RESOLUTION NO. R-033-2026

Resolution Setting Date for Public Hearing on Urban Renewal Plan Amendment for the Manchester Urban Renewal Area

WHEREAS, the City Council of the City of Manchester, Iowa by resolution previously established the Manchester Urban Renewal Area (the “Urban Renewal Area”) and adopted an urban renewal plan (the “Plan”) for the governance of initiatives and projects therein; and

WHEREAS, an amendment (the “Amendment”) to the Plan has been prepared which authorizes the undertaking of new urban renewal projects in the Urban Renewal Area consisting of (a) providing tax increment financing support to Henderson Properties, Inc. (“Henderson”) in connection with the construction by Henderson of a new warehouse for use in its business operations in the Urban Renewal Area and (b) providing tax increment financing support to Todd Summers (“Summers”) in connection with the construction by Summers of a meat locker and retail building for use in Summers’ business operations; and

WHEREAS, it is now necessary that a date be set for a public hearing on the Amendment;

NOW, THEREFORE, Be It Resolved by the City Council of the City of Manchester, Iowa, as follows:

Section 1. This City Council will meet at the City Council Chambers, 204 East Main Street, Manchester, Iowa, on April 27, 2026, at 5:00 p.m., at which time and place it will hold a public hearing on the proposed Amendment.

Section 2. The City Clerk shall publish notice of said hearing, the same being in the form attached hereto, which publication shall be made in a legal newspaper of general circulation in the City, which publication shall be not less than four (4) and not more than twenty (20) days before the date set for hearing.

Section 3. Pursuant to Section 403.5 of the Code of Iowa, the City Clerk and the City Manager, or their designees, are hereby designated as the City’s representatives in connection with the consultation process which is required under that section of the urban renewal law.

Passed and approved this March 23, 2026.

Mayor

Attest:

City Clerk

NOTICE OF PUBLIC HEARING ON PROPOSED URBAN RENEWAL PLAN
AMENDMENT

Notice Is Hereby Given: That at 5:00 p.m., at the City Council Chambers, 204 East Main Street, Manchester, Iowa, on April 27, 2026, the City Council of the City of Manchester, Iowa, will hold a public hearing on the question of amending the urban renewal plan for the Manchester Urban Renewal Area (the “Urban Renewal Area”) to authorize the undertaking of new urban renewal projects in the Urban Renewal Area consisting of (a) providing tax increment financing support to Henderson Properties, Inc. (“Henderson”) in connection with the construction by Henderson of a new warehouse for use in its business operations in the Urban Renewal Area and (b) providing tax increment financing support to Todd Summers (“Summers”) in connection with the construction by Summers of a meat locker and retail building for use in Summers’ business operations. A copy of the amendment is on file for public inspection in the office of the City Clerk.

At said hearing any interested person may file written objections or comments and may be heard orally with respect to the subject matters of the hearing.

Erin Learn
City Clerk

CITY OF MANCHESTER, IOWA
URBAN RENEWAL PLAN AMENDMENT
MANCHESTER URBAN RENEWAL AREA

April, 2026

The Urban Renewal Plan (the “Plan”) for the Manchester Urban Renewal Area (the “Urban Renewal Area”) of the City of Manchester, Iowa (the “City”) is being amended for the purpose of identifying new urban renewal projects to be undertaken in the Urban Renewal Area.

1) Identification of Project. By virtue of this amendment, the list of authorized urban renewal projects in the Plan is hereby amended to include the following project descriptions:

A.

Name of Project: Henderson Properties, Inc. Warehouse Project

Date of Council Approval of Project: April 27, 2026

Description of the Project and Project Site: Henderson Properties, Inc. (“Henderson”) has proposed to undertake the construction (the “Project”) of a new warehouse on certain real property located at 1085 South 3rd Street and bearing Delaware County Property Tax Parcel Identification Number 631323004300 (the “Henderson Property”) in the Urban Renewal Area for use in the business operations of a lawn care business.

It has been requested that the City provide tax increment financing assistance to Henderson in support of the efforts to complete the Project.

The costs incurred by the City in providing tax increment financing assistance to Henderson will include legal and administrative fees (the “Admin Fees”) in an amount not to exceed \$8,000.

Description of Use of TIF for the Project: The City intends to enter into a Development Agreement with Henderson with respect to the construction of the Project and to provide annual appropriation economic development payments (the “Payments”) to Henderson thereunder. The Payments will be funded with incremental property tax revenues to be derived from the Henderson Property. It is anticipated that the City’s total commitment of incremental property tax revenues with respect to the Project will not exceed \$450,000, plus the Admin Fees.

B.

Name of Project: The Manchester Locker Project

Date of Council Approval of Project: April 27, 2026

Description of the Project and Project Site: Todd Summers (“Summers”) has proposed to undertake the construction (the “Meat Locker Project”) of a new meat locker and retail building on certain real property located at 1101 South 5th Street and bearing Delaware County Property Tax Parcel Identification Numbers 630323002910 and 641323002900 (the “Summers Property”) in the Urban Renewal Area for use in the business operations of a meat locker.

It has been requested that the City provide tax increment financing assistance to Summers in support of the efforts to complete the Meat Locker Project.

The costs incurred by the City in providing tax increment financing assistance to Summers will include legal and administrative fees (the “Admin Fees”) in an amount not to exceed \$8,000.

Description of Use of TIF for the Project: The City intends to enter into a Development Agreement with Summers with respect to the construction of the Meat Locker Project and to provide annual appropriation economic development payments (the “Payments”) to Summers thereunder. The Payments will be funded with incremental property tax revenues to be derived from the Summers Property. It is anticipated that the City’s total commitment of incremental property tax revenues with respect to the Meat Locker Project will not exceed \$600,000, plus the Admin Fees.

2) Required Financial Information. The following information is provided in accordance with the requirements of Section 403.17 of the Code of Iowa:

Constitutional debt limit of the City:	<u>\$25,797,817</u>
Outstanding general obligation debt of the City:	<u>\$ 6,475,000</u>
Proposed debt to be incurred under the April, 2026 Amendment*:	<u>\$ 1,066,000</u>

* It is anticipated that some or all of the debt incurred hereunder will be subject to annual appropriation by the City Council.

R-034-2026
RESOLUTION AMENDING SALARY RESOLUTION

BE IT HEREBY RESOLVED BY THE CITY COUNCIL OF THE CITY OF MANCHESTER

SECTION 1. That the following employee having obtained her Staff Certification from the State Library of Iowa be granted an increase and be paid as follows:

Employee	Position	Hourly Rate	Effective
Cindy Ries	Children's Librarian	\$20.25	03/09/2026

All other requirements shall be the same as that set out in Resolution R-059-2025 as passed and approved on June 30th, 2025.

PASSED AND APPROVED this 23rd day of March, 2026.

Connie Behnken, Mayor

ATTEST:

Erin Learn, City Clerk



108 N. Franklin Street
Manchester, IA 52057

INVOICE

Invoice No: 492
Terms: Net 45
Invoice Date: 3/10/2026
Due Date: 4/9/2026

Bill To:

City of Manchester
208 East Main Street
Manchester, IA 52057

Project: Baum Park Shelter					
Billing Phase:	Scheduled Value:	Work Completed		% Complete:	Balance to Finish:
		From Previous Invoices:	Current Billing:		
Construction Documents	\$7,855.75	\$7,855.75	\$0.00	100%	\$0.00
Bidding	\$938.00	\$0.00	\$938.00	100%	\$0.00
Construction Phase	\$2,931.25	\$0.00	\$0.00	0%	\$2,931.25
	\$11,725.00	\$7,855.75	\$938.00		\$2,931.25

Total this Invoice: \$938.00

Outstanding Invoices		
Number:	Date:	Amount:
Total Outstanding:		\$0.00

Total Now Due: \$938.00

LETTING DATE
MARCH 17, 2026

PCC TRAIL
TAP-R-4682(629)--8T-28

CITY OF MANCHESTER



TRANSPORTATION DEVELOPMENT DIVISION
PLANS OF PROPOSED IMPROVEMENTS FOR THE
TRANSPORTATION DEVELOPMENT DIVISION

PCC TRAIL

CITY OF MANCHESTER

IOWA DOT PROJECT NO. TAP-R-4682(629)--8T-28

STATE	FMHA REGION	F.Y.	SHEET	TOTAL
IOWA	7	2027	1	12
PROJECT NUMBER				
TAP-R-4682(629)--8T-28				
PIN NUMBER				

BURRINGTON GROUP, INC.
Civil Engineering | Land Surveying
105 W. Main Street Manchester, Iowa 52057
Phone 563-927-2434 burringtongroup.com

INDEX OF SHEETS	
A.01	TITLE SHEET
A.02	LEGEND SHEET
A.03	OVERALL PLAN
B.01	TYPICAL SECTIONS
C.01	TABULATIONS
C.02	TABULATIONS
C.03	TABULATIONS
D.01	TRAIL PLAN & PROFILE - STA 0+00 TO 5+50
D.02	TRAIL PLAN & PROFILE - STA 5+50 TO 11+00
D.03	TRAIL PLAN & PROFILE - STA 11+00 TO 16+50
D.04	TRAIL PLAN & PROFILE - STA 16+50 TO 21+85
S.01	SIDEWALK PLAN

Refer to the Proposal Form for list of applicable specifications.

PROJECT DESCRIPTION:
In the city of Manchester, Grand Ave Trl ext, trail begins at E Fairview Dr, south to E Acers St.

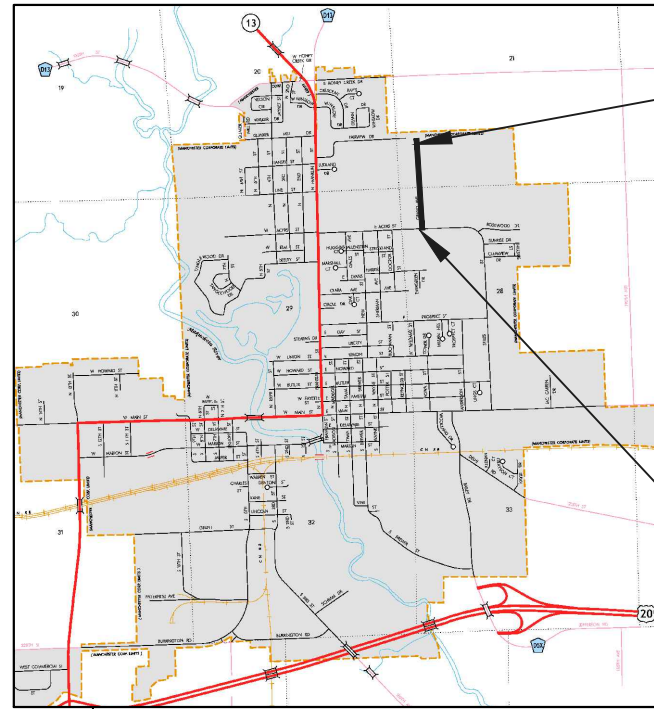

END OF PROJECT
STA 21+85

BEGINNING OF PROJECT
STA 0+00

MILEAGE SUMMARY			
DIV.	LOCATION	LIN. FT.	MILES
-	GRAND AVE - MANCHESTER, IOWA STA 0+00 TO STA 21+85	2,185	0.41

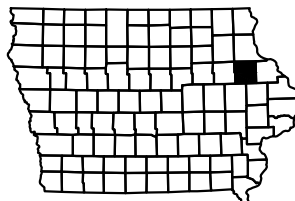

LOCATION MAP
NOT TO SCALE

I HEREBY CERTIFY THAT THIS ENGINEERING DOCUMENT WAS PREPARED BY ME OR UNDER MY DIRECT PERSONAL SUPERVISION AND THAT I AM A DULY LICENSED PROFESSIONAL ENGINEER UNDER THE LAWS OF THE STATE OF IOWA

Jason A. Wenger 12/9/2025
Jason A. Wenger, P.E. IOWA REG. NO. 20436 DATE
My License Renewal Date is December 31, 2026
PAGES OR SHEETS COVERED BY THIS SEAL: 12

PROPOSED UTILITIES & LINES

PROPOSED CENTERLINE	
PROPOSED CONTOUR	
PROPOSED INDEX CONTOUR	
PROPOSED CURB LINE	
PROPOSED STORM LINE	
PROPOSED WATER MAIN	
PROPOSED SANITARY MAIN	
PROPOSED WATER SERVICE LINE	
PROPOSED SEWER SERVICE LINE	
PROPOSED SUBDRAIN	
PROPOSED UNDERGROUND ELECTRICAL	
PROPOSED P.C. PAVEMENT	
PROPOSED STORM INTAKE	
PROPOSED APRON	
PROPOSED SANITARY MANHOLE	
PROPOSED STORM MANHOLE	
PROPOSED FIRE HYDRANT	
PROPOSED VALVE BOX	
PROPOSED CURB BOX	
PROPOSED LITE POLE	
PROPOSED SIGN	
SOIL BORING LOCATION	
PROPOSED SUBDRAIN	

SURVEYING LINES

LOT LINE	
EASEMENT LINE	
QUARTER LINE	
QUARTER-QUARTER LINE	
FOUND MONUMENT	
SET MONUMENT	
SUBDIVISION BOUNDARY	

EXISTING LINES & UTILITIES

TOP BANK LINE	
DITCH LINE	
EXISTING FARM LANE LINE	
EXISTING CONTOUR LINE	
EXISTING INDEX CONTOUR LINE	
EDGE OF PAVEMENT LINE	
OVERHEAD ELECTRIC LINE	
EXISTING STORM LINE	
EXISTING TILE LINE	
EXISTING WATER MAIN LINE	
EXISTING SEWER LINE	
EXISTING SEWER SERVICE	
EXISTING SIDEWALK	
EXISTING ASPHALT SURFACE	
EXISTING CONCRETE SURFACE	
EXISTING GRANULAR SURFACE	
EXISTING RIP RAP/BOULDERS	
EXISTING BUILDING	
EXISTING UTILITY POLE & GUY WIRE	
EXISTING TREE	
EXISTING RETAINING WALL/FOUNDATION	
EXISTING MANHOLE	
EXISTING PIPE APRON	
EXISTING INTAKE	
EXISTING FIRE HYDRANT	
EXISTING VALVE BOX	

PROPOSED EROSION & SEDIMENT CONTROL

PROPOSED SILT FENCING	
PROPOSED EROSION MAT	
PROPOSED RIP RAP/EROSION STONE	
PROPOSED DIVERSION DIKE	
PROPOSED SEDIMENT TRAP	

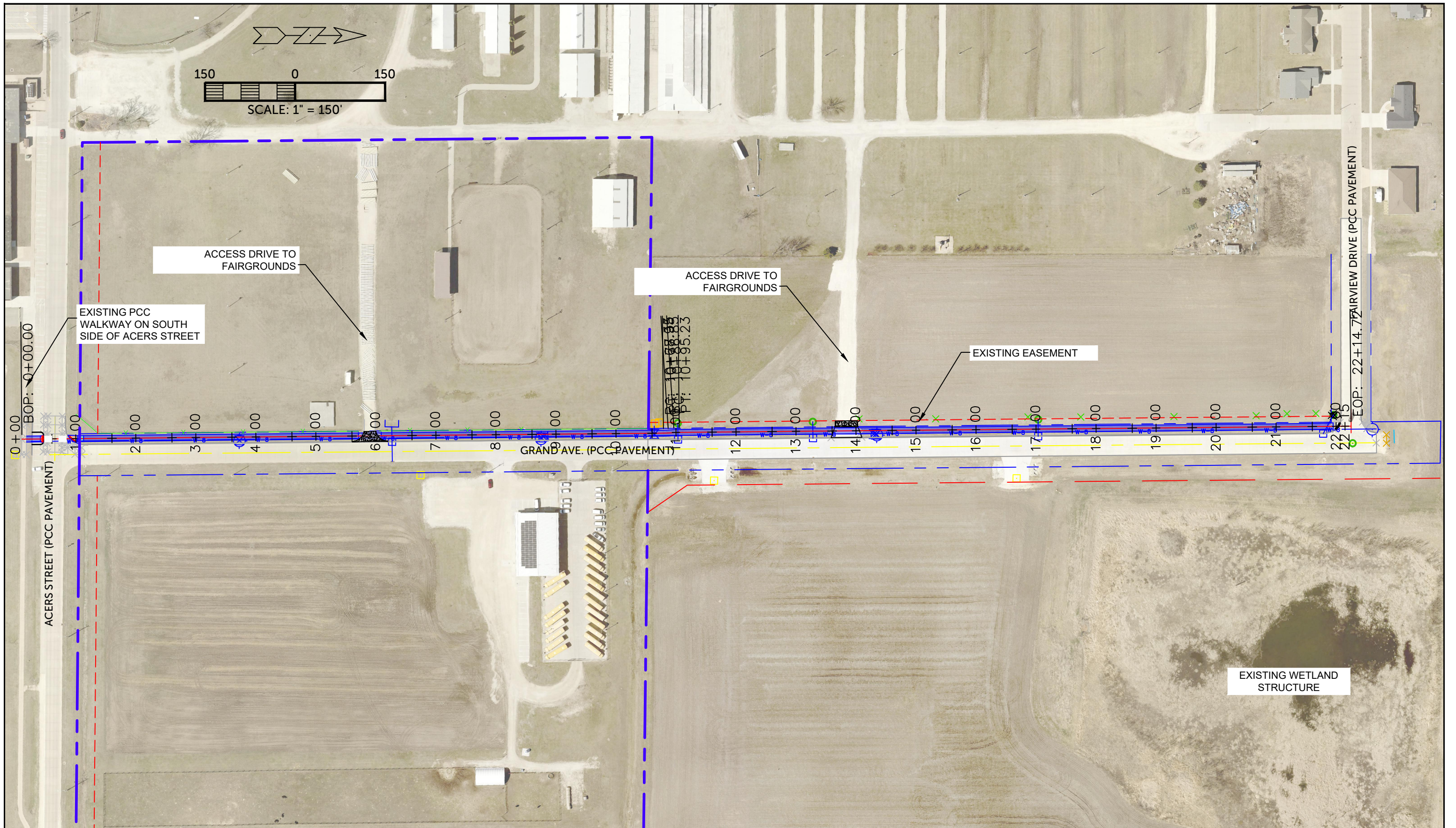

BURRINGTON GROUP, INC.
 Civil Engineering | Land Surveying
 105 W. Main Street Manchester, Iowa 52057
 Phone 563-927-2434 burringtongroup.com

DRAWN BY: JAW APPROVED BY: JAW
 DATE: 12/9/2025 PROJECT NO: 24-150

PROJECT **GRAND AVENUE TRAIL EXTENSION**
TAP-R-4682(629)--8T-28
MANCHESTER, IA

SHEET NAME
OVERALL PLAN

SHEET NO. OF
A.03 12

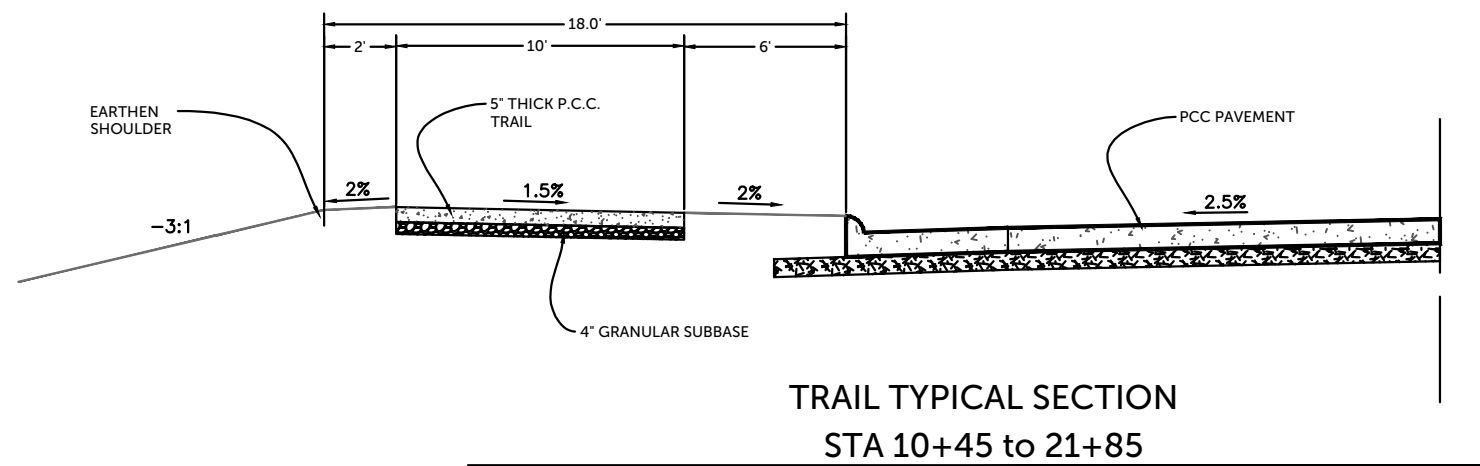
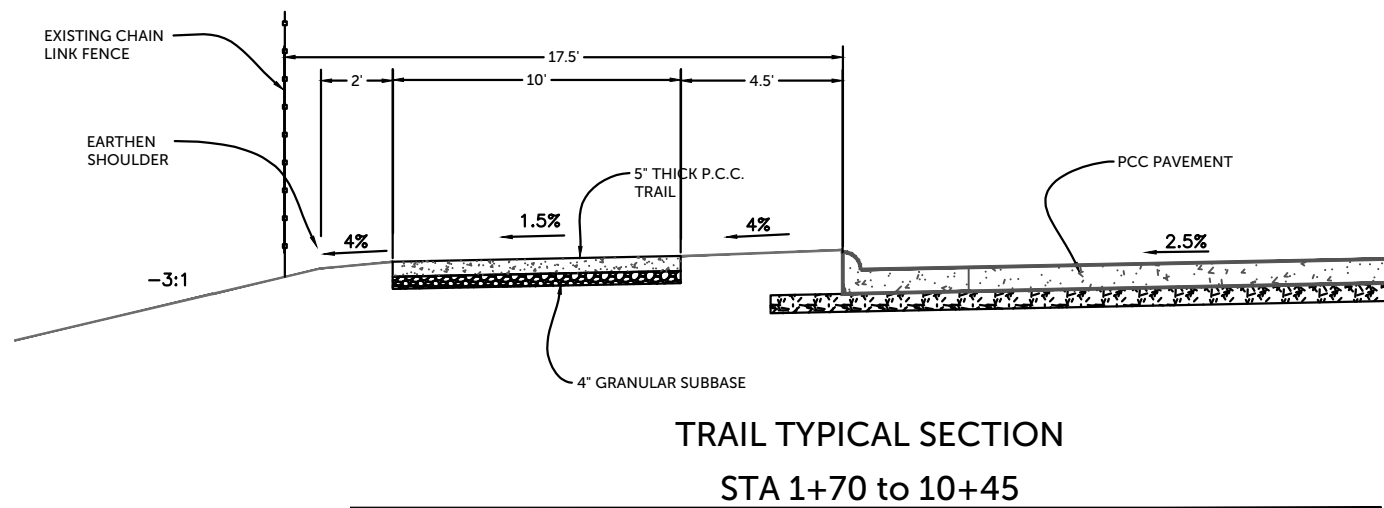
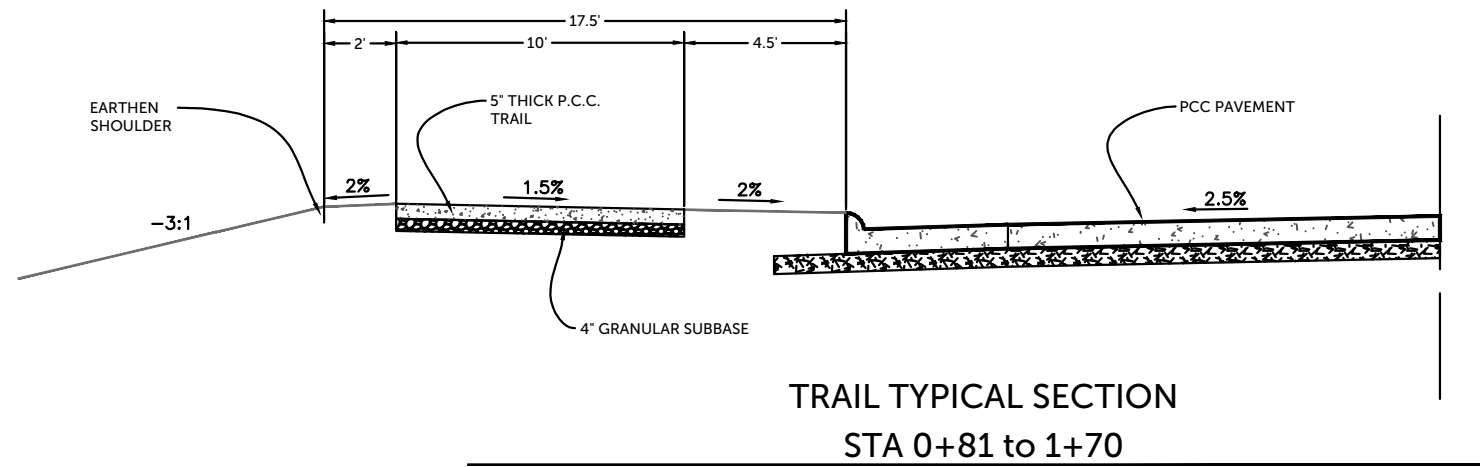

ESTIMATED PROJECT QUANTITIES AND REFERENCE NOTES					
Item No.	Item Code	Item	Unit	Division 1	Estimate Reference Notes
1	2102-0425070	SPECIAL BACKFILL	TON	710	Refer to Typical Sections. Item to be used for temporary surfacing, if necessary. Quantity assumes 4" under PCC Trail, 6" under driveways.
2	2102-2625000	EMBANKMENT-IN-PLACE	CY	480	Provide borrow material according to Section 2102 of the Standard Specifications. Material shall be provided by the Contractor.
3	2102-2710070	EXCAVATION, CLASS 10, ROADWAY AND BORROW	CY	820	Includes excavation of subgrade under PCC trail and driveways for special backfill; excavation/shaping from back of curb to edge of proposed trail and from trail to toe of slope. Item to be paid for by plan quantity.
4	2105-8425015	TOPSOIL, STRIP, SALVAGE AND SPREAD	CY	600	Assumes 6" stripping thickness required within grading limits. Minimum respread thickness is 4"
5	2123-7450020	SHOULDER FINISHING, EARTH	STA	37.5	Includes shaping shoulder as shown in typical sections. Material for earth shoulders is included in the earthwork quantities.
6	2510-6745850	REMOVAL OF PAVEMENT	SY	90	Refer to sheet D.01. Item includes HMA and PCC pavement removal and offsite disposal. Approximate PCC thickness is 8". Approximate HMA thickness is 5".
7	2511-0302500	RECREATIONAL TRAIL, PORTLAND CEMENT CONCRETE, 5 IN.	SY	2298	See typical section, sheet B.01. Certified Plant Inspection required.
8	2511-0302600	RECREATIONAL TRAIL, PORTLAND CEMENT CONCRETE, 6 IN.	SY	19.9	To be used at ramps/landings under detectable warnings at Acers Street intersection. See Sheet S.01. Certified Plant Inspection required.
9	2511-7528101	DETECTABLE WARNINGS	SF	52	Unfinished cast iron required. See sheet S.01 for details. Rectangular panels on south side of Acers Street and factory radiused panels on N. side of Acers Street, 30' curb radius
10	2512-1725256	CURB AND GUTTER, P.C. CONCRETE, 2.5 FT.	LF	28	See plan sheet D.01 for location at new curb island adjacent to pavement patch on south side of Acers Street. Certified Plant Inspection required.
11	2515-2475008	DRIVEWAY, P.C. CONCRETE, 8 IN.	SY	97.9	See tabulation sheet C.03 and plan sheets D.02 & D.03 for details. Certified Plant Inspection required.
12	2527-9263209	PAINTED PAVEMENT MARKINGS, WATERBORNE OR SOLVENT-BASED	STA	6.2	See tabulation sheet C.03. Item to be used for cross walk striping at Acers Street. Continental block to match trail width and have 18" painted bar and 18" space.
13	2528-8445110	TRAFFIC CONTROL	LS	1	Acers Street and Grand Avenue to remain open to traffic at all times. Refer to Traffic Control notes on Sheet C.02
14	2529-5070110	PATCHES, FULL-DEPTH FINISH, BY AREA	SY	43.8	See plan sheet D.01. Certified Plant Inspection required.
15	2529-5070120	PATCHES, FULL-DEPTH FINISH, BY COUNT	EACH	2	See plan sheet D.01
16	2533-4980005	MOBILIZATION	LS	1	
17	2601-2634110	MULCHING, MECHANICALLY-BONDED FIBER MATRIX	ACRE	0.5	Measurement will be by the acre of area mulched.
18	2601-2642120	STABILIZING CROP - SEEDING AND FERTILIZING (URBAN)	ACRE	0.5	Item is included for disturbed areas as directed by the Engineer. Seed and fertilize all urban disturbed areas according to Article 2601.03, C, 2, of the Standard Specifications.
19	2602-0000020	SILT FENCE	LF	1200	Refer to Tab. 100-17. The tabulation includes estimated locations for placement of "Silt Fence" to address erosion to be encountered during construction. Verify the specific locations with the Engineer prior to beginning placement. Bid item includes tab quantity for the paving project. See Standard Road Plan EC-201. The engineer may adjust silt fence locations to fit field conditions.
20	2602-0000312	PERIMETER AND SLOPE SEDIMENT CONTROL DEVICE, 12 IN. DIA.	LF	3230	Refer to Tab. 100-19. The tabulation includes estimated locations for placement of "Perimeter and Slope Sediment Control Device, 12 in. dia." to address erosion to be encountered during construction. Verify the specific locations with the Engineer prior to beginning placement. Bid item includes 10% additional quantity for field adjustments and replacements. Use Perimeter and Slope Sediment Control Devices fabricated using wood excelsior.
21	2602-0000351	REMOVAL OF PERIMETER AND SLOPE OR DITCH CHECK SEDIMENT CONTROL DE	LF	4430	



BURRINGTON GROUP, INC.
Civil Engineering | Land Surveying
105 W. Main Street Manchester, Iowa 52057
Phone 563-927-2434 burringtongroup.com

DRAWN BY: JAW APPROVED BY: JAW
DATE: 12/9/2025 PROJECT NO: 24-150

PROJECT **GRAND AVENUE TRAIL EXTENSION**
TAP-R-4682(629)--8T-28
MANCHESTER, IA

SHEET NAME
TABULATIONS

SHEET NO.
C.01

OF
12

DWG:

STANDARD ROAD PLANS

The following Standard Road Plans apply to construction work on this project.

Number	Date	Title
EC-201	4-20-21	Silt Fence
EC-204	10-19-21	Perimeter and Slope Sediment Control Devices
EW-101	10-17-17	Embankments and Rebuilding Embankments
EW-403	4-18-17	Temporary Erosion Control Measures
MI-210	10-21-25	PCC Driveways and Alleys
MI-220	4-15-25	Detectable Warnings and Pedestrian Ramp
PM-110	10-15-24	Line Types
PR-103	10-15-25	Full Depth PCC Patch with Dowels
PV-101	10-21-25	Joints
PV-102	10-21-25	Curb Details
TC-1	10-15-19	Work Not Affecting Traffic (Two-Lane or Multi-Lane)
TC-61	10-21-25	Two-Lane, Two-way Operation
TC-202	4-18-23	Work Within 15 ft of Traveled Way
TC-211	10-15-19	Lane Closure on Low Volume Roadway
TC-233	10-17-17	Pavement Marking Operations Two-Lane
TC-602	10-15-19	Sidewalk Diversion

111-25

INDEX OF TABULATIONS

Tabulation	Tabulation Title	Sheet No.
C Sheets		
100-1C	ESTIMATED PROJECT QUANTITIES	C.01
100-1D	PROJECT DESCRIPTION	A.01
100-4A	ESTIMATE REFERENCE INFORMATION	C.01
100-11	EROSION CONTROL FOR INTAKE OR MANHOLE WELL	C.02
100-17	TABULATION OF SILT FENCES	C.02
102-3	ACCESS DRIVES AND SAFETY RAMPS	C.03
105-4	STANDARD ROAD PLANS	C.02
108-22	PAVEMENT MARKING LINE TYPES	C.03
111-25	INDEX OF TABULATIONS	C.02
111-25	INDEX OF TABULATIONS	C.02
113-1	SIDEWALKS	S-Sheet
232-30	EROSION CONTROL (URBAN SEEDING)	C.02
290-01	SIDEWALK CONSTRAINTS	C.02

UTILITIES

STORM SEWER
 JASON HAIGHT, CITY OF MANCHESTER
 563.927.4011
 208 E. MAIN STREET
 MANCHESTER, IA 52057
 comiastreetdept@gmail.com

WATER
 CHAD WULFEKUHLE, CITY OF MANCHESTER
 563.927.4011
 208 E. MAIN STREET
 MANCHESTER, IA 52057
 comiawaterdept@gmail.com

PERIMETER AND SLOPE SEDIMENT CONTROL DEVICE

100-19
04-19-16

Possible Standards: EC-204

Location			Length of Installation			Remarks
Begin Station	End Station	Side	9 inch Dia	12 inch Dia	20 inch Dia	
			LF	LF	LF	
0+74	5+69	L		495.0		Adjacent to exiting chain link fence
5+90	10+45	L		455.0		Adjacent to exiting chain link fence
0+89	5+50	R		461.0		Adjacent to back of curb on Grand Avenue
6+08	13+48	R		740.0		Adjacent to back of curb on Grand Avenue
14+00	21+87	R		787.0		Adjacent to back of curb on Grand Avenue

EROSION CONTROL (URBAN SEEDING)

232-3B
10-20-15

Following the completion of work in a disturbed area, place seed, fertilizer, and mulch on the disturbed area as follows:

Use seed mix and fertilizer meeting the requirements of Article 2601.03,C,4 and Section 4169 of the Standard Specifications.

Use mulch meeting the requirements of Articles 2601.03,E,2,a and 4169.07,A of the Standard Specifications.

Preparing the seedbed and furnishing and applying seed, fertilizer, and mulch is incidental to mobilization and will not be paid for separately.

SIDEWALK CONSTRAINTS

290-01
04-15-14

- Widths:
Widths listed in the S sheets are minimums.
- Cross Slopes:
Construct all sidewalks, curb ramps, and landings/turning spaces at a target cross slope of 1.5%. Cross slopes exceeding 2.0% will not be allowed, except for areas tying into existing pavement. In these areas, transition from existing pavement cross slope to a cross slope of less than 2.0% within one panel at a rate not to exceed 1.0% per foot.
- Longitudinal Slopes:
 - Sidewalk:
 - Roadway slope exceeds 5.0%: Sidewalk longitudinal slope exceeding the roadway slope by more than 2.0% will not be allowed.
 - Roadway slope 5.0% or less: Sidewalk longitudinal slope exceeding 5.0% will not be allowed.
 - Ramps:
 - Ramps 15.0' in length or less: Longitudinal slope exceeding 8.3% will not be allowed.
 - Ramps greater than 15.0' in length: Construct with the longitudinal slope necessary to conform to the design.
- Landing/Turning Spaces:
Longitudinal slopes exceeding 2.0% will not be allowed.

TABULATION OF SILT FENCES

Refer to EC-201

Location			Length LF	Remarks
Begin Station	End Station	Side		
10+45	13+55	LT	310.0	
13+92	21+82	LT	790.0	

TRAFFIC CONTROL PLAN

Traffic shall be maintained on Acers Street, Grand Avenue & Fairview Drive during construction.

Traffic control shall be in accordance with TC-001, TC-061, TC-202, TC-211, TC-233 and TC-602 as appropriate.

Access to Fairgrounds driveways being paved as a part of the project shall be coordinated. One driveway at a time allowed to be closed during paving operations.

Existing Acers street walkway to remain open as long as practicable. If trail closure is required, all work shall comply with current ADA requirements. For closures, contractor shall provide Type II barricad meeting requirements of NCHRP Report 350 across full width of trail.

CONSTRUCTION SURVEY TO BE PROVIDED BY OWNER. (NOT A BID ITEM)

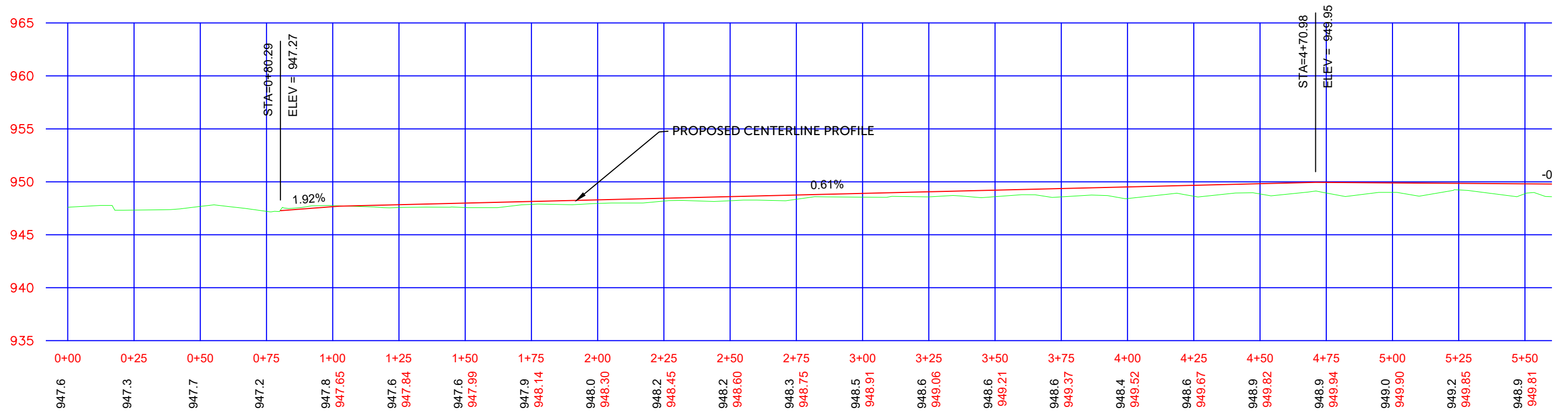
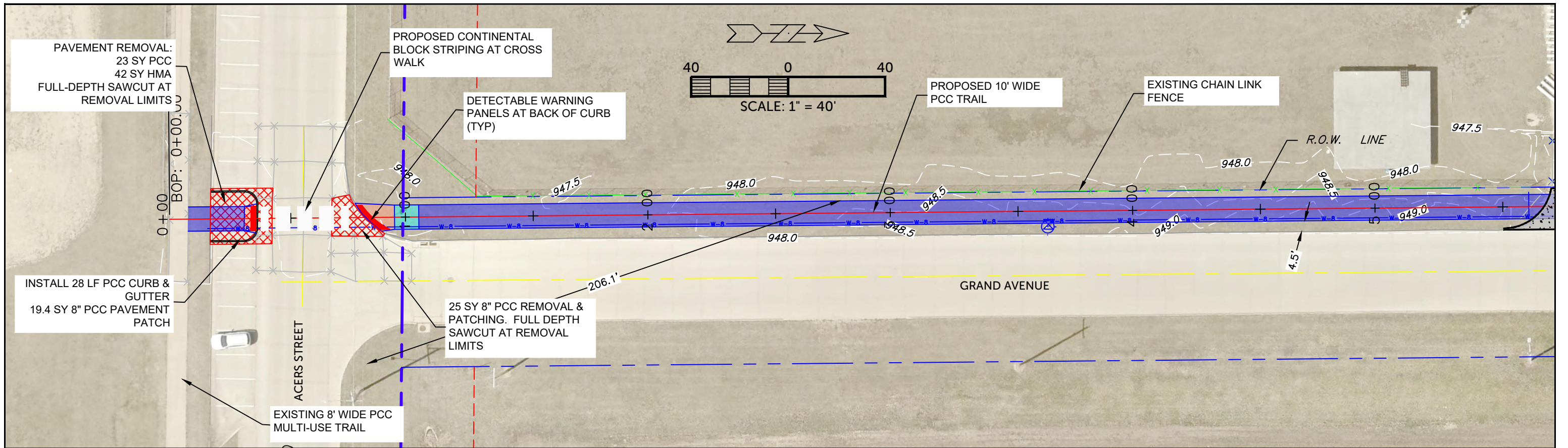

BURRINGTON GROUP, INC.
Civil Engineering | Land Surveying
105 W. Main Street Manchester, Iowa 52057
Phone 563-927-2434 burringtongroup.com

DRAWN BY: JAW APPROVED BY: JAW
DATE: 12/9/2025 PROJECT NO: 24-150

PROJECT **GRAND AVENUE TRAIL EXTENSION**
TAP-R-4682(629)--8T-28
MANCHESTER, IA

SHEET NAME **TRAIL - STA 0+00**
TO 5+50

SHEET NO. **D.01** OF **12**

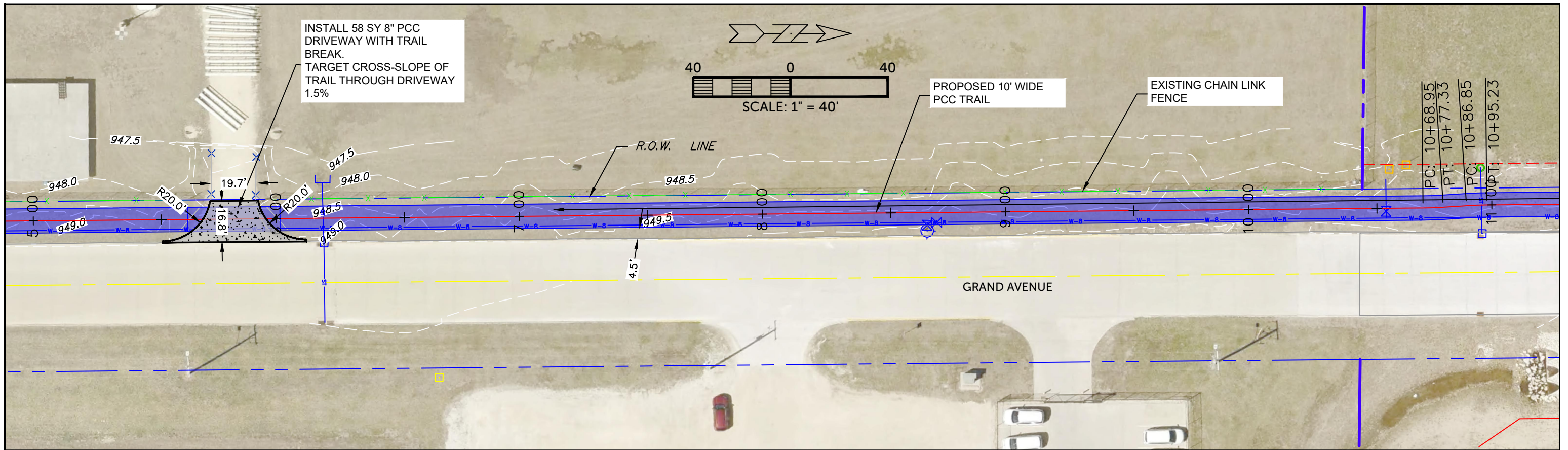

INSTALL 58 SY 8" PCC DRIVEWAY WITH TRAIL BREAK.
TARGET CROSS-SLOPE OF TRAIL THROUGH DRIVEWAY 1.5%

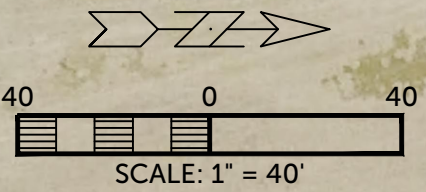

PROPOSED 10' WIDE PCC TRAIL

EXISTING CHAIN LINK FENCE

GRAND AVENUE

PC: 10+68.95
PT: 10+77.33
PC: 10+86.85
PT: 10+95.23

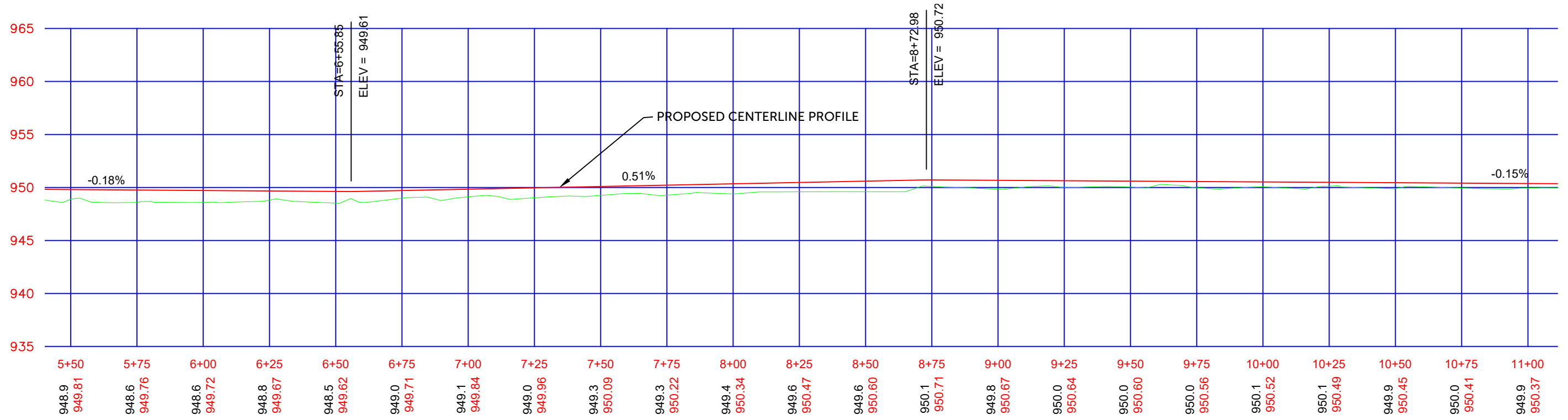

BURRINGTON GROUP, INC.
Civil Engineering | Land Surveying
105 W. Main Street Manchester, Iowa 52057
Phone 563-927-2434 burringtongroup.com

DRAWN BY: JAW APPROVED BY: JAW
DATE: 12/9/2025 PROJECT NO: 24-150

PROJECT **GRAND AVENUE TRAIL EXTENSION**
TAP-R-4682(629)--8T-28
MANCHESTER, IA

SHEET NAME **TRAIL - STA 5+50 TO 11+00**

SHEET NO. **D.02** OF **12**

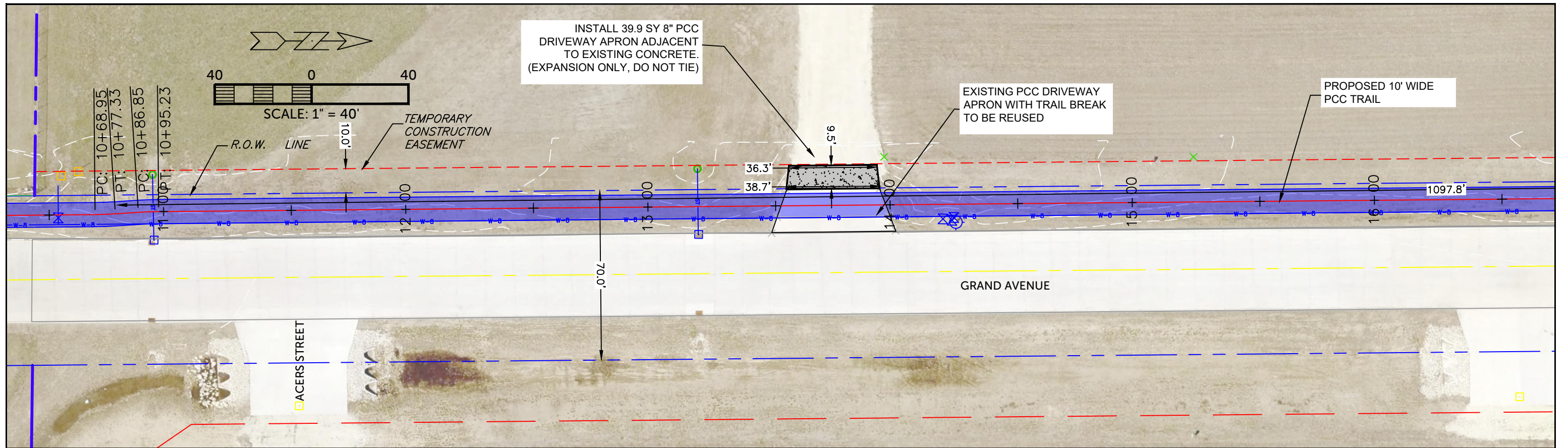

INSTALL 39.9 SY 8" PCC DRIVEWAY APRON ADJACENT TO EXISTING CONCRETE. (EXPANSION ONLY, DO NOT TIE)

EXISTING PCC DRIVEWAY APRON WITH TRAIL BREAK TO BE REUSED

PROPOSED 10' WIDE PCC TRAIL

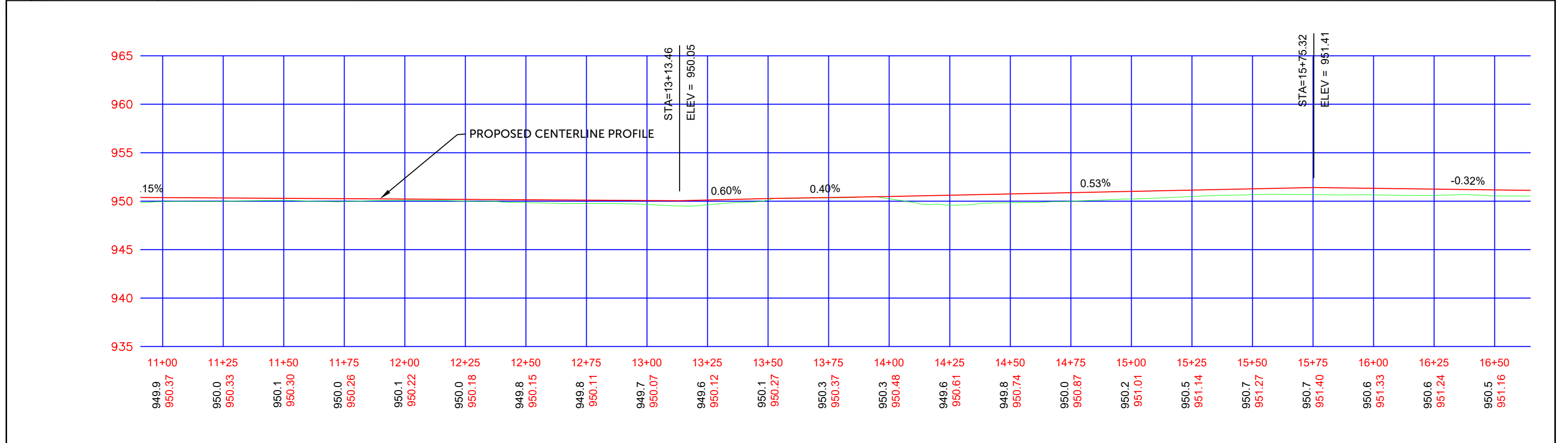
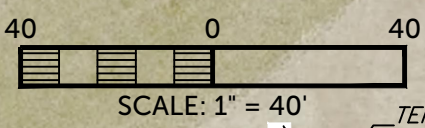

BURRINGTON GROUP, INC.
 Civil Engineering | Land Surveying
 105 W. Main Street Manchester, Iowa 52057
 Phone 563-927-2434 burringtongroup.com

DRAWN BY: JAW APPROVED BY: JAW
 DATE: 12/9/2025 PROJECT NO: 24-150

PROJECT **GRAND AVENUE TRAIL EXTENSION**
TAP-R-4682(629)--8T-28
MANCHESTER, IA

SHEET NAME **TRAIL - STA 11+00 TO 16.50**

SHEET NO. **D.03** OF **12**

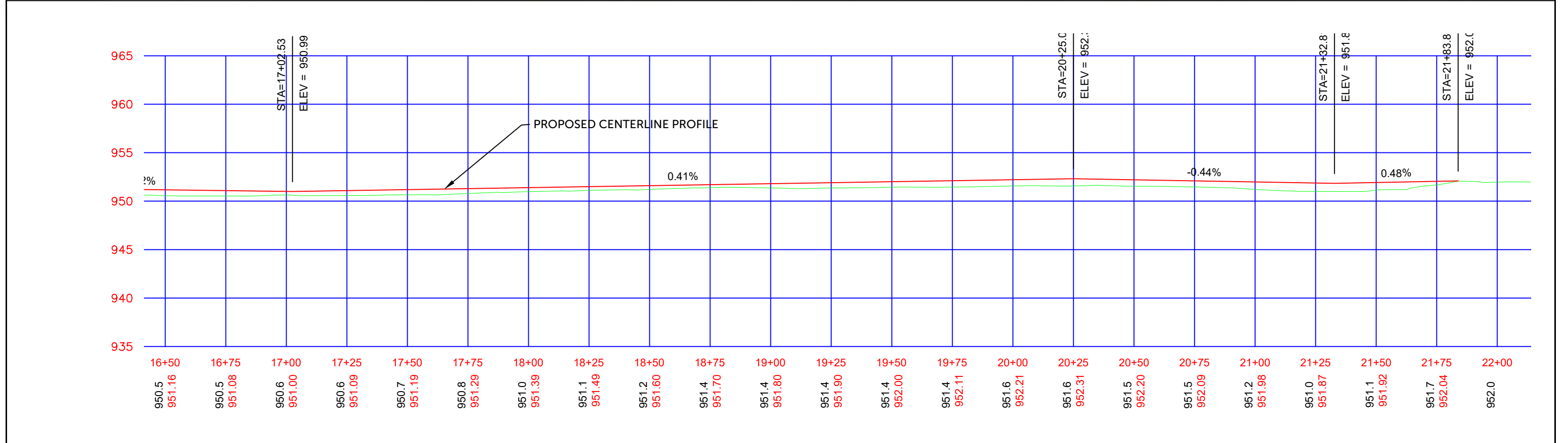
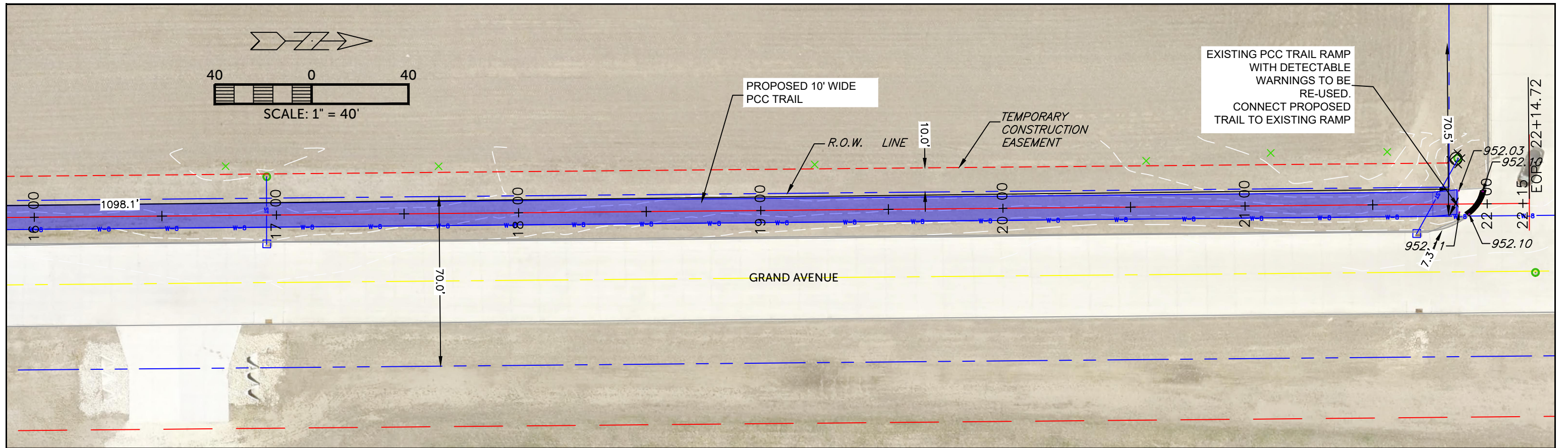

BURRINGTON GROUP, INC.
 Civil Engineering | Land Surveying
 105 W. Main Street Manchester, Iowa 52057
 Phone 563-927-2434 burringtongroup.com

DRAWN BY: JAW APPROVED BY: JAW
 DATE: 12/9/2025 PROJECT NO: 24-150

PROJECT **GRAND AVENUE TRAIL EXTENSION**
TAP-R-4682(629)--8T-28
MANCHESTER, IA

SHEET NAME **TRAIL - STA 16+50**
TO 21+85

SHEET NO. **D.04** OF **12**

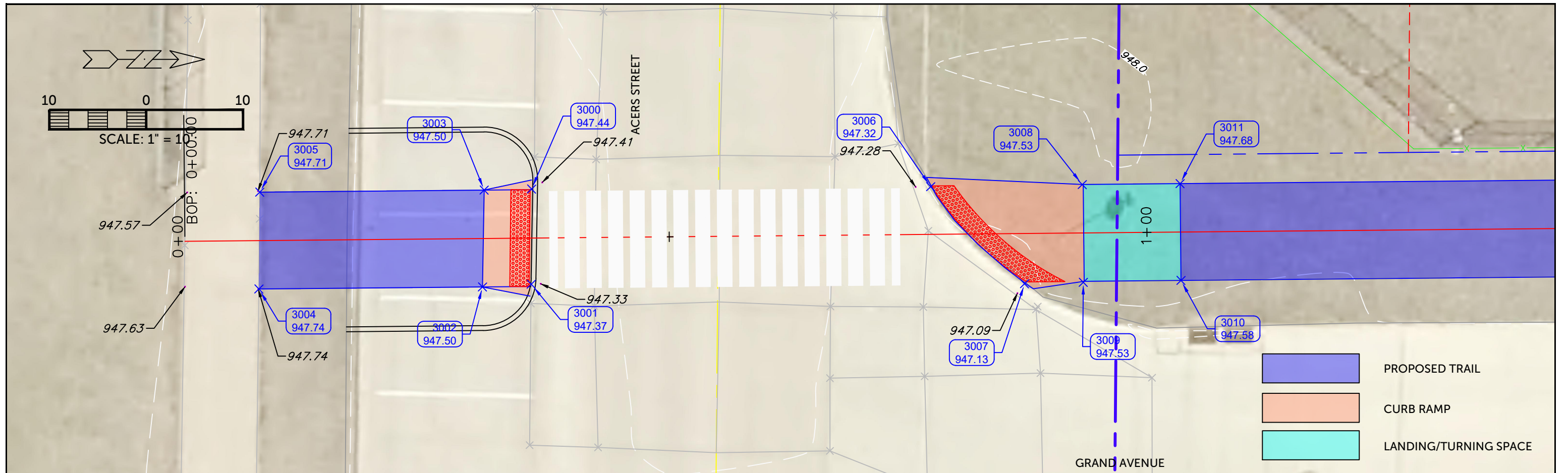

SIDEWALK COMPLIANCE

See S Sheets

* Does not include curb
 Staking required by Contracting Authority per Article 2511.03 of the Standard Specifications.
 Refer to tabulation 113-01 for bid quantities.

Point to Point	Sidewalk Designation	_" PCC Sidewalk (2)	Distance* FT	Δ Elevation FT	Slope %	Acceptable Constructed Range Pos. or Neg.	Staking Required on this Quadrant? (1)	Measured Slope %	Initial s	Remarks	FOR INFORMATION ONLY: VALUES USED TO DETERMINE DESIGNED SLOPES			
											Point	Station	Offset	Elevation
3000	3001 Sidewalk Cross Slope	6	10	0.07	0.7	0.1% to 2.0%					3000			947.44
3000	3003 Ramp Running Slope	6	5	0.06	1.2	0.5% to 8.3%	Yes				3001			947.37
3001	3002 Ramp Running Slope	6	5	0.13	2.6	0.5% to 8.3%	Yes				3002			947.5
3003	3005 Sidewalk Running Slope	5	23	0.21	0.9	0.5% to 5.0%					3003			947.5
3002	3004 Sidewalk Running Slope	5	23	0.24	1.0	0.5% to 5.0%					3004			947.74
3004	3005 Match Existing Cross Slope	5	10	0.03	0.3	0.1% to 2.0%					3005			947.74
											3006			947.32
3006	3007 Sidewalk Cross Slope	6	13.6	0.19	1.4	0.1% to 2.0%					3007			947.13
3006	3008 Ramp Running Slope	6	15.6	0.21	1.3	0.5% to 8.3%	Yes				3008			947.53
3007	3009 Ramp Running Slope	6	5	0.4	8.0	0.5% to 8.3%	Yes				3009			947.53
3008	3011 Landing	5	10	0.15	1.5	0.1% to 2.0%					3010			947.58
3009	3010 Landing	5	10	0.05	0.5	0.1% to 2.0%					3011			947.68
3010	3011 Sidewalk Cross Slope	5	10	0.1	1	0.1% to 2.0%								

BURRINGTON GROUP, INC.
 Civil Engineering | Land Surveying
 105 W. Main Street Manchester, Iowa 52057
 Phone 563-927-2434 burringtongroup.com

DRAWN BY: JAW APPROVED BY: JAW
 DATE: 12/9/2025 PROJECT NO: 24-150

PROJECT **GRAND AVENUE TRAIL EXTENSION**
TAP-R-4682(629)--8T-28
MANCHESTER, IA

SHEET NAME
SIDEWALK PLAN

SHEET NO. **S.01** OF **12**

Grand Avenue Trail Project

as of 03/17/2026

Estimated Costs

Engineering	\$	64,000
Construction	\$	199,862
Construction Contingency (15%)	\$	29,979
Total	\$	293,841

Proposed Funding

TAP Grant Funds (80% of construction)	\$183,873
Local Option Sales Tax (Walkway portion)	\$109,968
Total	\$293,841

RESOLUTION NO. R-035-2026

Resolution Approving and Confirming Plans, Specifications, Form of Contract and Estimate of Cost for the Grand Avenue Trail Project

WHEREAS, the City Council of the City of Manchester, Iowa, has heretofore given preliminary approval to the plans, specifications, form of contract and estimate of cost (the "Contract Documents") for the proposed Grand Avenue Trail Project (the "Project"), as described in the notice of hearing on the Contract Documents for the Project; and

WHEREAS, a hearing has been held on the Contract Documents on March 23, 2026;

NOW, THEREFORE, Be It Resolved by the City Council of the City of Manchester, Iowa, as follows:

Section 1. The Contract Documents referred to in the preamble hereof are hereby finally approved, and the prior action of the City Council giving preliminary approval is hereby finally confirmed, and the Project, as provided for in the Contract Documents, is necessary and desirable.

Section 2. All resolutions or parts of resolutions in conflict herewith are hereby repealed to the extent of such conflict.

Passed and approved March 23, 2026.

Connie Behnken, Mayor

Attest:

Erin Learn, City Clerk

LETTING DATE
MARCH 17, 2026

PCC TRAIL
TAP-R-4682(629)--8T-28

CITY OF MANCHESTER



TRANSPORTATION DEVELOPMENT DIVISION
PLANS OF PROPOSED IMPROVEMENTS FOR THE
TRANSPORTATION DEVELOPMENT DIVISION

PCC TRAIL

CITY OF MANCHESTER

IOWA DOT PROJECT NO. TAP-R-4682(629)--8T-28

STATE	FMHA REGION	F.Y.	SHEET	TOTAL
IOWA	7	2027	1	12
PROJECT NUMBER				
TAP-R-4682(629)--8T-28				
PIN NUMBER				

BURRINGTON GROUP, INC.
Civil Engineering | Land Surveying
105 W. Main Street Manchester, Iowa 52057
Phone 563-927-2434 burringtongroup.com

INDEX OF SHEETS	
A.01	TITLE SHEET
A.02	LEGEND SHEET
A.03	OVERALL PLAN
B.01	TYPICAL SECTIONS
C.01	TABULATIONS
C.02	TABULATIONS
C.03	TABULATIONS
D.01	TRAIL PLAN & PROFILE - STA 0+00 TO 5+50
D.02	TRAIL PLAN & PROFILE - STA 5+50 TO 11+00
D.03	TRAIL PLAN & PROFILE - STA 11+00 TO 16+50
D.04	TRAIL PLAN & PROFILE - STA 16+50 TO 21+85
S.01	SIDEWALK PLAN

Refer to the Proposal Form for list of applicable specifications.

PROJECT DESCRIPTION:
In the city of Manchester, Grand Ave Trl ext, trail begins at E Fairview Dr, south to E Acers St.

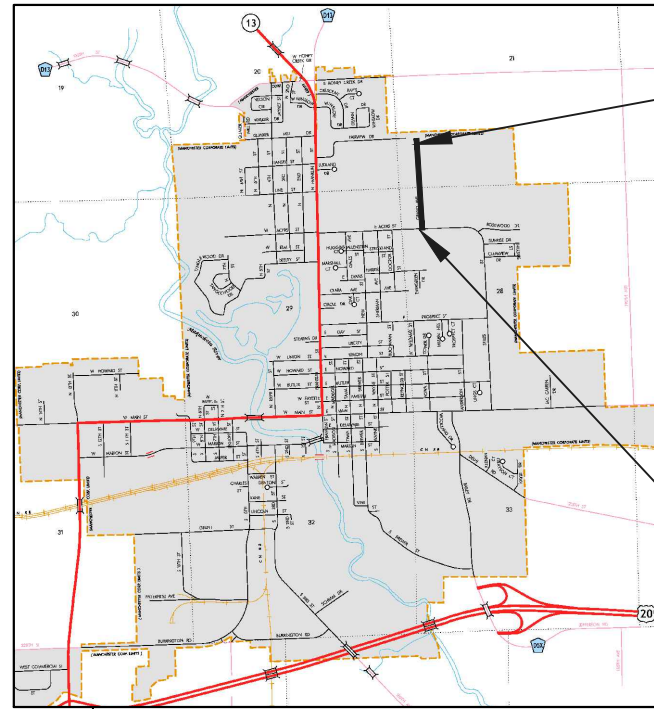

END OF PROJECT
STA 21+85

BEGINNING OF PROJECT
STA 0+00

MILEAGE SUMMARY			
DIV.	LOCATION	LIN. FT.	MILES
-	GRAND AVE - MANCHESTER, IOWA STA 0+00 TO STA 21+85	2,185	0.41

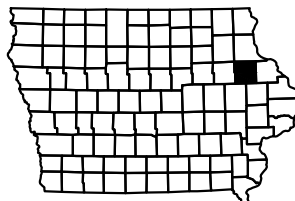

LOCATION MAP
NOT TO SCALE

I HEREBY CERTIFY THAT THIS ENGINEERING DOCUMENT WAS PREPARED BY ME OR UNDER MY DIRECT PERSONAL SUPERVISION AND THAT I AM A DULY LICENSED PROFESSIONAL ENGINEER UNDER THE LAWS OF THE STATE OF IOWA

Jason A. Wenger 12/9/2025
Jason A. Wenger, P.E. IOWA REG. NO. 20436 DATE
My License Renewal Date is December 31, 2026
PAGES OR SHEETS COVERED BY THIS SEAL: 12

PROPOSED UTILITIES & LINES

PROPOSED CENTERLINE	
PROPOSED CONTOUR	
PROPOSED INDEX CONTOUR	
PROPOSED CURB LINE	
PROPOSED STORM LINE	
PROPOSED WATER MAIN	
PROPOSED SANITARY MAIN	
PROPOSED WATER SERVICE LINE	
PROPOSED SEWER SERVICE LINE	
PROPOSED SUBDRAIN	
PROPOSED UNDERGROUND ELECTRICAL	
PROPOSED P.C. PAVEMENT	
PROPOSED STORM INTAKE	
PROPOSED APRON	
PROPOSED SANITARY MANHOLE	
PROPOSED STORM MANHOLE	
PROPOSED FIRE HYDRANT	
PROPOSED VALVE BOX	
PROPOSED CURB BOX	
PROPOSED LITE POLE	
PROPOSED SIGN	
SOIL BORING LOCATION	
PROPOSED SUBDRAIN	

SURVEYING LINES

LOT LINE	
EASEMENT LINE	
QUARTER LINE	
QUARTER-QUARTER LINE	
FOUND MONUMENT	
SET MONUMENT	
SUBDIVISION BOUNDARY	

EXISTING LINES & UTILITIES

TOP BANK LINE	
DITCH LINE	
EXISTING FARM LANE LINE	
EXISTING CONTOUR LINE	
EXISTING INDEX CONTOUR LINE	
EDGE OF PAVEMENT LINE	
OVERHEAD ELECTRIC LINE	
EXISTING STORM LINE	
EXISTING TILE LINE	
EXISTING WATER MAIN LINE	
EXISTING SEWER LINE	
EXISTING SEWER SERVICE	
EXISTING SIDEWALK	
EXISTING ASPHALT SURFACE	
EXISTING CONCRETE SURFACE	
EXISTING GRANULAR SURFACE	
EXISTING RIP RAP/BOULDERS	
EXISTING BUILDING	
EXISTING UTILITY POLE & GUY WIRE	
EXISTING TREE	
EXISTING RETAINING WALL/FOUNDATION	
EXISTING MANHOLE	
EXISTING PIPE APRON	
EXISTING INTAKE	
EXISTING FIRE HYDRANT	
EXISTING VALVE BOX	

PROPOSED EROSION & SEDIMENT CONTROL

PROPOSED SILT FENCING	
PROPOSED EROSION MAT	
PROPOSED RIP RAP/EROSION STONE	
PROPOSED DIVERSION DIKE	
PROPOSED SEDIMENT TRAP	

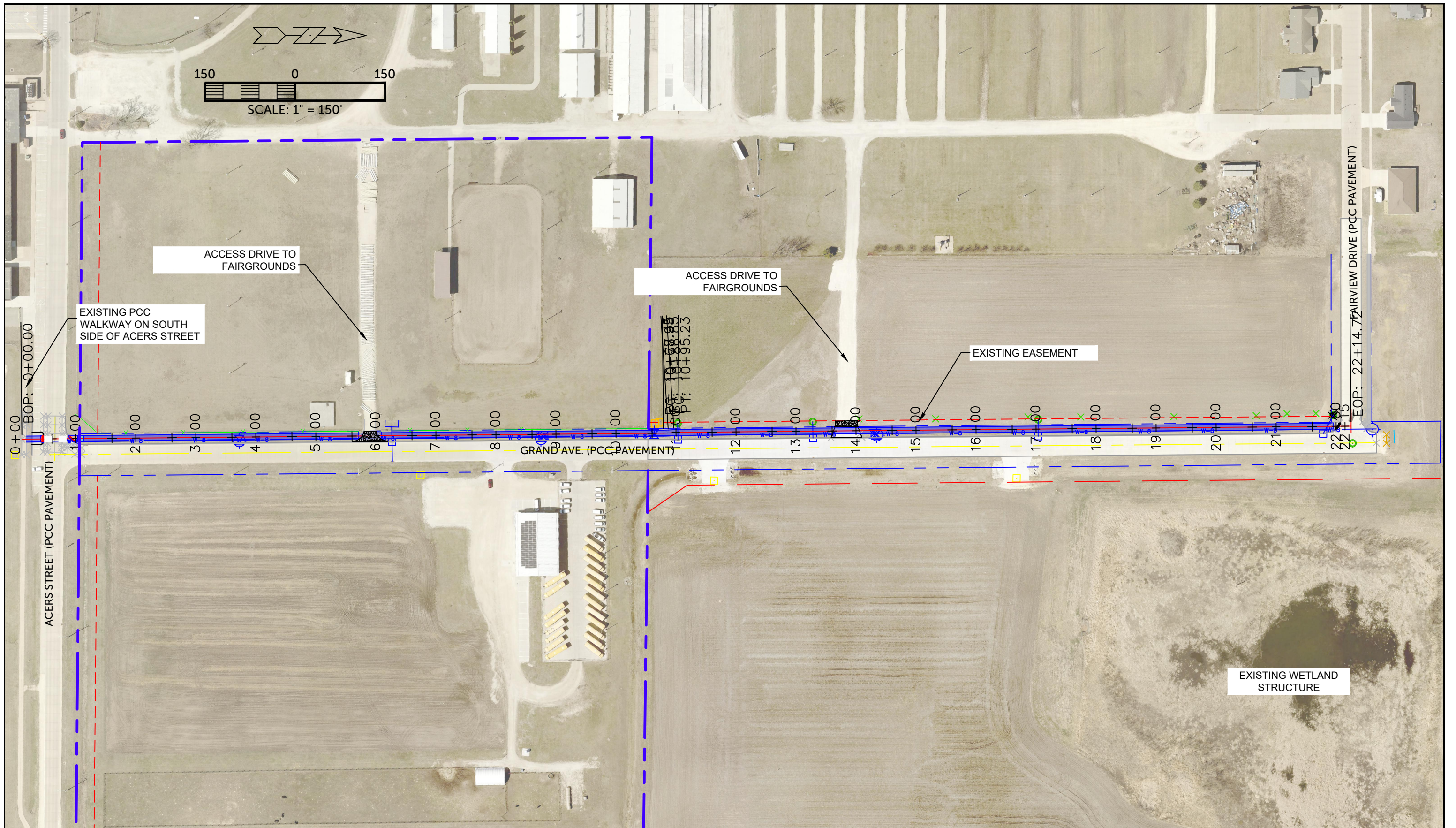

BURRINGTON GROUP, INC.
 Civil Engineering | Land Surveying
 105 W. Main Street Manchester, Iowa 52057
 Phone 563-927-2434 burringtongroup.com

DRAWN BY: JAW APPROVED BY: JAW
 DATE: 12/9/2025 PROJECT NO: 24-150

PROJECT **GRAND AVENUE TRAIL EXTENSION**
TAP-R-4682(629)--8T-28
MANCHESTER, IA

SHEET NAME
OVERALL PLAN

SHEET NO. OF
A.03 12

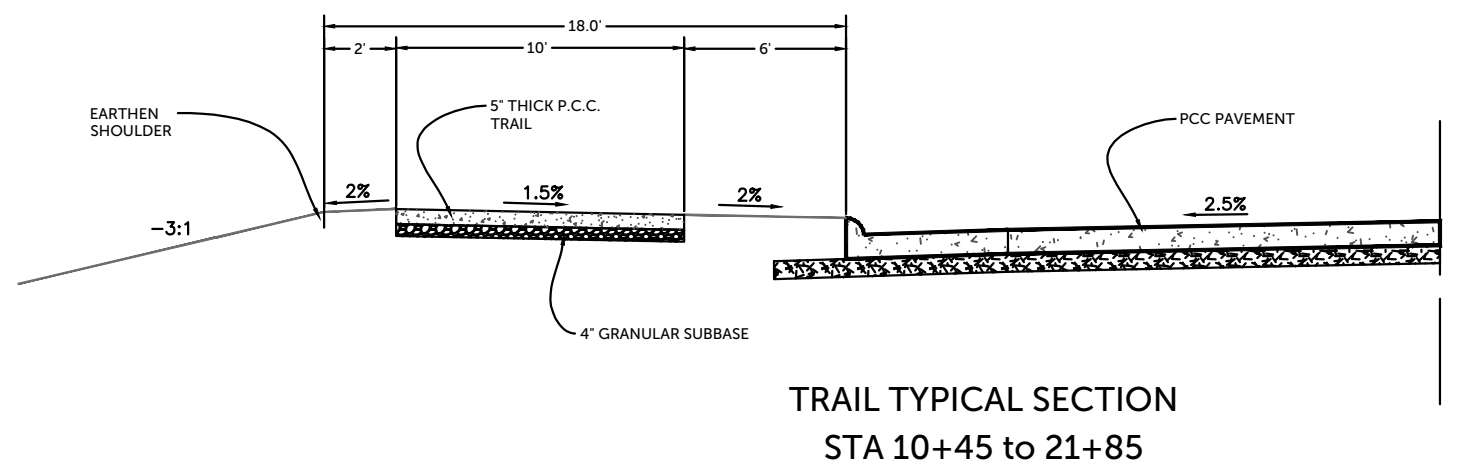
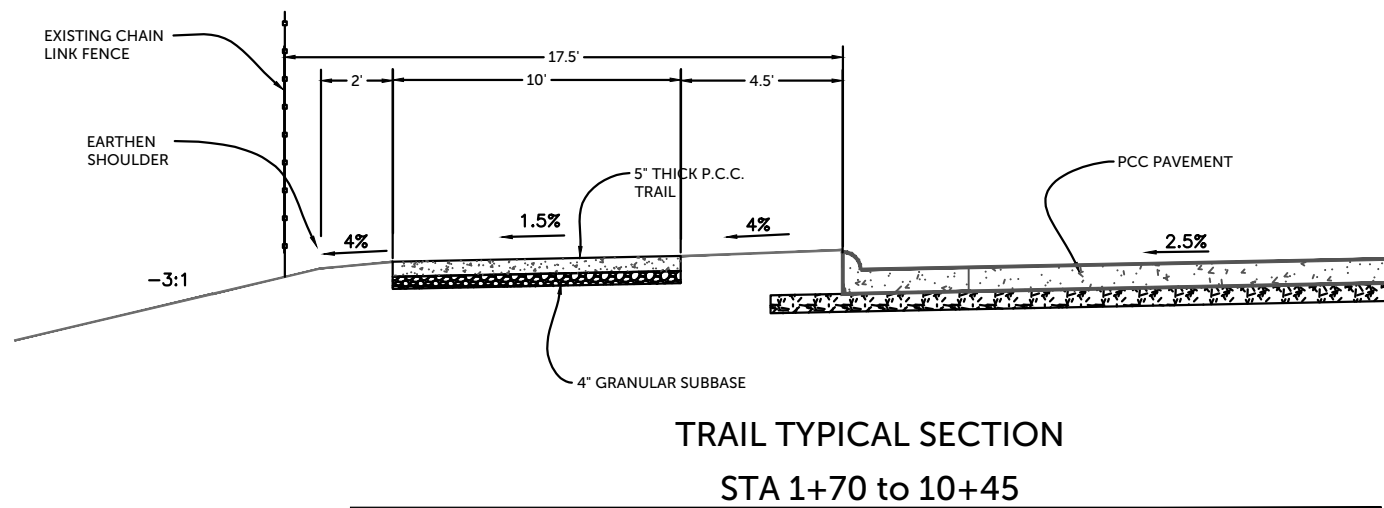
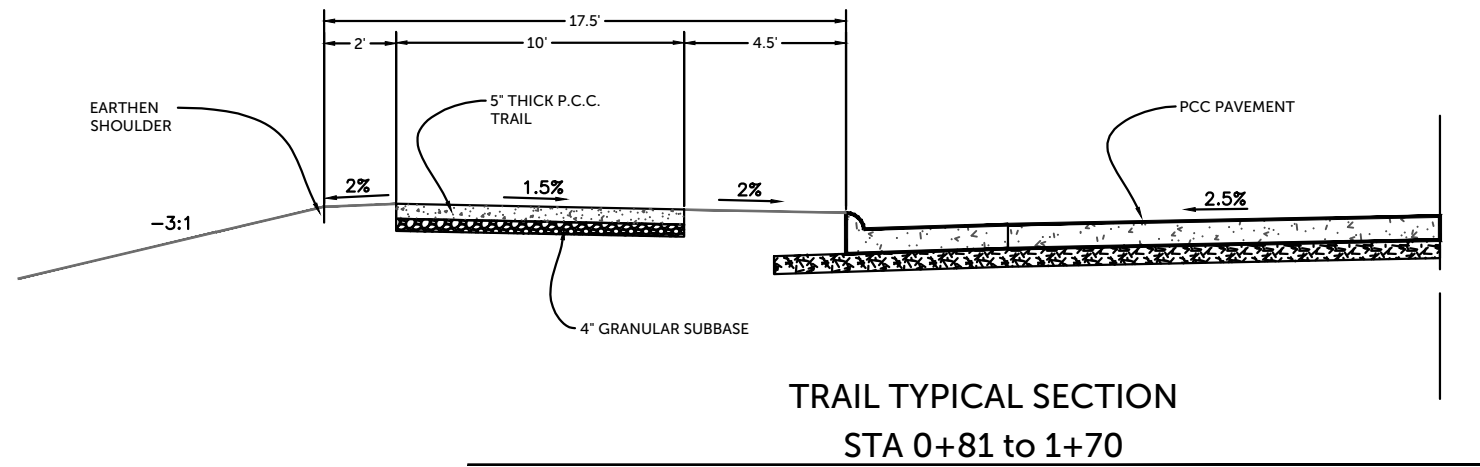

ESTIMATED PROJECT QUANTITIES AND REFERENCE NOTES					
Item No.	Item Code	Item	Unit	Division 1	Estimate Reference Notes
1	2102-0425070	SPECIAL BACKFILL	TON	710	Refer to Typical Sections.Â Item to be used for temporary surfacing, if necessary.Â Quantity assumes 4" under PCC Trail, 6" under driveways.
2	2102-2625000	EMBANKMENT-IN-PLACE	CY	480	Provide borrow material according to Section 2102 of the Standard Specifications. Material shall be provided by the Contractor.
3	2102-2710070	EXCAVATION, CLASS 10, ROADWAY AND BORROW	CY	820	Includes excavation of subgrade under PCC trail and driveways for special backfill; excavation/shaping from back of curb to edge of proposed trail and from trail to toe of slope.Â Item to be paid for by plan quantity.
4	2105-8425015	TOPSOIL, STRIP, SALVAGE AND SPREAD	CY	600	Assumes 6" stripping thickness required within grading limits.Â Minimum respread thickness is 4"
5	2123-7450020	SHOULDER FINISHING, EARTH	STA	37.5	Includes shaping shoulder as shown in typical sections. Material for earth shoulders is included in the earthwork quantities.
6	2510-6745850	REMOVAL OF PAVEMENT	SY	90	Refer to sheet D.01.Â Item includes HMA and PCC pavement removal and offsite disposal. Approximate PCC thickness is 8". Approximate HMA thickness is 5".
7	2511-0302500	RECREATIONAL TRAIL, PORTLAND CEMENT CONCRETE, 5 IN.	SY	2298	See typical section, sheet B.01. Certified Plant Inspection required.
8	2511-0302600	RECREATIONAL TRAIL, PORTLAND CEMENT CONCRETE, 6 IN.	SY	19.9	To be used at ramps/landings under detectable warnings at Acers Street intersection.Â See Sheet S.01. Certified Plant Inspection required.
9	2511-7528101	DETECTABLE WARNINGS	SF	52	Unfinished cast iron required.Â See sheet S.01 for details.Â Rectangular panels on south side of Acers Street and factory radiused panels on N. side of Acers Street, 30' curb radius
10	2512-1725256	CURB AND GUTTER, P.C. CONCRETE, 2.5 FT.	LF	28	See plan sheet D.01 for location at new curb island adjacent to pavement patch on south side of Acers Street. Certified Plant Inspection required.
11	2515-2475008	DRIVEWAY, P.C. CONCRETE, 8 IN.	SY	97.9	See tabulation sheet C.03 and plan sheets D.02 & D.03 for details. Certified Plant Inspection required.
12	2527-9263209	PAINTED PAVEMENT MARKINGS, WATERBORNE OR SOLVENT-BASED	STA	6.2	See tabulation sheet C.03.Â Item to be used for cross walk striping at Acers Street.Â Continental block to match trail width and have 18" painted bar and 18" space.
13	2528-8445110	TRAFFIC CONTROL	LS	1	Acers Street and Grand Avenue to remain open to traffic at all times.Â Refer to Traffic Control notes on Sheet C.02
14	2529-5070110	PATCHES, FULL-DEPTH FINISH, BY AREA	SY	43.8	See plan sheet D.01. Certified Plant Inspection required.
15	2529-5070120	PATCHES, FULL-DEPTH FINISH, BY COUNT	EACH	2	See plan sheet D.01
16	2533-4980005	MOBILIZATION	LS	1	
17	2601-2634110	MULCHING, MECHANICALLY-BONDED FIBER MATRIX	ACRE	0.5	Measurement will be by the acre of area mulched. Item is included for disturbed areas as directed by the Engineer.
18	2601-2642120	STABILIZING CROP - SEEDING AND FERTILIZING (URBAN)	ACRE	0.5	Seed and fertilize all urban disturbed areas according to Article 2601.03, C, 2, of the Standard Specifications.
19	2602-0000020	SILT FENCE	LF	1200	Refer to Tab. 100-17. The tabulation includes estimated locations for placement of "Silt Fence" to address erosion to be encountered during construction. Verify the specific locations with the Engineer prior to beginning placement. Bid item includes tab quantity for the paving project. See Standard Road Plan EC-201. The engineer may adjust silt fence locations to fit field conditions.
20	2602-0000312	PERIMETER AND SLOPE SEDIMENT CONTROL DEVICE, 12 IN. DIA.	LF	3230	Refer to Tab. 100-19. The tabulation includes estimated locations for placement of "Perimeter and Slope Sediment Control Device, 12 in. dia." to address erosion to be encountered during construction. Verify the specific locations with the Engineer prior to beginning placement. Bid item includes 10% additional quantity for field adjustments and replacements. Use Perimeter and Slope Sediment Control Devices fabricated using wood excelsior.
21	2602-0000351	REMOVAL OF PERIMETER AND SLOPE OR DITCH CHECK SEDIMENT CONTROL DE	LF	4430	



BURRINGTON GROUP, INC.
Civil Engineering | Land Surveying
105 W. Main Street Manchester, Iowa 52057
Phone 563-927-2434 burringtongroup.com

DRAWN BY: JAW	APPROVED BY: JAW
DATE: 12/9/2025	PROJECT NO: 24-150

PROJECT **GRAND AVENUE TRAIL EXTENSION**
TAP-R-4682(629)--8T-28
MANCHESTER, IA

SHEET NAME **TABULATIONS**

SHEET NO. **C.01**

OF **12**

DWG:

STANDARD ROAD PLANS

The following Standard Road Plans apply to construction work on this project.

Number	Date	Title
EC-201	4-20-21	Silt Fence
EC-204	10-19-21	Perimeter and Slope Sediment Control Devices
EW-101	10-17-17	Embankments and Rebuilding Embankments
EW-403	4-18-17	Temporary Erosion Control Measures
MI-210	10-21-25	PCC Driveways and Alleys
MI-220	4-15-25	Detectable Warnings and Pedestrian Ramp
PM-110	10-15-24	Line Types
PR-103	10-15-25	Full Depth PCC Patch with Dowels
PV-101	10-21-25	Joints
PV-102	10-21-25	Curb Details
TC-1	10-15-19	Work Not Affecting Traffic (Two-Lane or Multi-Lane)
TC-61	10-21-25	Two-Lane, Two-way Operation
TC-202	4-18-23	Work Within 15 ft of Traveled Way
TC-211	10-15-19	Lane Closure on Low Volume Roadway
TC-233	10-17-17	Pavement Marking Operations Two-Lane
TC-602	10-15-19	Sidewalk Diversion

111-25

INDEX OF TABULATIONS

Tabulation	Tabulation Title	Sheet No.
C Sheets		
100-1C	ESTIMATED PROJECT QUANTITIES	C.01
100-1D	PROJECT DESCRIPTION	A.01
100-4A	ESTIMATE REFERENCE INFORMATION	C.01
100-11	EROSION CONTROL FOR INTAKE OR MANHOLE WELL	C.02
100-17	TABULATION OF SILT FENCES	C.02
102-3	ACCESS DRIVES AND SAFETY RAMPS	C.03
105-4	STANDARD ROAD PLANS	C.02
108-22	PAVEMENT MARKING LINE TYPES	C.03
111-25	INDEX OF TABULATIONS	C.02
111-25	INDEX OF TABULATIONS	C.02
113-1	SIDEWALKS	S-Sheet
232-30	EROSION CONTROL (URBAN SEEDING)	C.02
290-01	SIDEWALK CONSTRAINTS	C.02

UTILITIES

STORM SEWER
 JASON HAIGHT, CITY OF MANCHESTER
 563.927.4011
 208 E. MAIN STREET
 MANCHESTER, IA 52057
 comiastreetdept@gmail.com

WATER
 CHAD WULFEKUHLE, CITY OF MANCHESTER
 563.927.4011
 208 E. MAIN STREET
 MANCHESTER, IA 52057
 comiawaterdept@gmail.com

PERIMETER AND SLOPE SEDIMENT CONTROL DEVICE

100-19
04-19-16

Possible Standards: EC-204

Location			Length of Installation			Remarks
Begin Station	End Station	Side	9 inch Dia	12 inch Dia	20 inch Dia	
			LF	LF	LF	
0+74	5+69	L		495.0		Adjacent to exiting chain link fence
5+90	10+45	L		455.0		Adjacent to exiting chain link fence
0+89	5+50	R		461.0		Adjacent to back of curb on Grand Avenue
6+08	13+48	R		740.0		Adjacent to back of curb on Grand Avenue
14+00	21+87	R		787.0		Adjacent to back of curb on Grand Avenue

EROSION CONTROL (URBAN SEEDING)

232-3B
10-20-15

Following the completion of work in a disturbed area, place seed, fertilizer, and mulch on the disturbed area as follows:

Use seed mix and fertilizer meeting the requirements of Article 2601.03,C,4 and Section 4169 of the Standard Specifications.

Use mulch meeting the requirements of Articles 2601.03,E,2,a and 4169.07,A of the Standard Specifications.

Preparing the seedbed and furnishing and applying seed, fertilizer, and mulch is incidental to mobilization and will not be paid for separately.

SIDEWALK CONSTRAINTS

290-01
04-15-14

- Widths:
Widths listed in the S sheets are minimums.
- Cross Slopes:
Construct all sidewalks, curb ramps, and landings/turning spaces at a target cross slope of 1.5%. Cross slopes exceeding 2.0% will not be allowed, except for areas tying into existing pavement. In these areas, transition from existing pavement cross slope to a cross slope of less than 2.0% within one panel at a rate not to exceed 1.0% per foot.
- Longitudinal Slopes:
 - Sidewalk:
 - Roadway slope exceeds 5.0%: Sidewalk longitudinal slope exceeding the roadway slope by more than 2.0% will not be allowed.
 - Roadway slope 5.0% or less: Sidewalk longitudinal slope exceeding 5.0% will not be allowed.
 - Ramps:
 - Ramps 15.0' in length or less: Longitudinal slope exceeding 8.3% will not be allowed.
 - Ramps greater than 15.0' in length: Construct with the longitudinal slope necessary to conform to the design.
- Landing/Turning Spaces:
Longitudinal slopes exceeding 2.0% will not be allowed.

TABULATION OF SILT FENCES

Refer to EC-201

Location			Length LF	Remarks
Begin Station	End Station	Side		
10+45	13+55	LT	310.0	
13+92	21+82	LT	790.0	

TRAFFIC CONTROL PLAN

Traffic shall be maintained on Acers Street, Grand Avenue & Fairview Drive during construction.
 Traffic control shall be in accordance with TC-001, TC-061, TC-202, TC-211, TC-233 and TC-602 as appropriate.
 Access to Fairgrounds driveways being paved as a part of the project shall be coordinated. One driveway at a time allowed to be closed during paving operations.
 Existing Acers street walkway to remain open as long as practicable. If trail closure is required, all work shall comply with current ADA requirements. For closures, contractor shall provide Type II barricad meeting requirements of NCHRP Report 350 across full width of trail.

CONSTRUCTION SURVEY TO BE PROVIDED BY OWNER. (NOT A BID ITEM)

PAVEMENT MARKING LINE TYPES

See PM-110

*BCY4 - Place on the same side of the roadway to match existing markings near the project.
**NPY4 - For estimating purposes only. No Passing Zone Lines will be located in the field.

***MNY4 - Factor of 1.00 as value includes number of 4-inch passes to cover median nose area.

BCY4: Broken Centerline (Yellow) @ 0.25
ELY4: Edge Line Left (Yellow) @ 1.00

DCY4: Double Centerline (Yellow) @ 2.00
CBW6: Crosswalk Bar (White) @ 15.00

NPY4: No Passing Zone Line (Yellow) @ 1.25
CLW6: Crosswalk Line (White) @ 3.00

BLW4: Broken Lane Line (White) @ 0.25
SLW2: Stop Line (White) @ 6.00

ELW4: Edge Line Right (White) @ 1.00

Location			Length by Line Type (Unfactored)																	Remarks							
Road ID	Station to Station		Dir. of Travel	Marking Type	Side			BCY4*	DCY4	NPY4**	BLW4	ELW4	ELY4	CBW6	CLW6	SLW2											
					L	C	R	STA	STA	STA	STA	STA	STA	STA	STA	STA	STA	STA	STA		STA	STA	STA	STA			
Acers Street	+36.50	+78.50	BOTH	Waterborne/Solvent Paint			x																			10' Wide, 5' each side CL	
				Factored Total: Waterborne/Solvent Paint			-	-	-	-	-	-	-	-	-	-	-	-	-	-	-	-	-	-	-	-	
				Bid Quantity: Painted Pavement Markings, Waterborne or Solvent-Based							6.30																

ACCESS POINTS AND SAFETY RAMPS

Refer to Cross-Sections

Length of unclassified pipe calculated is based on using Reinforced Concrete Pipe.

- ① Refer to MI-210
- ② Refer to EW-501.
- ③ Refer to EW-501 or EW-502.

*Predetermined for access point not constructed with this project.

Location		Type	Length of Opening ①			Pipe Culvert ③			Aprons	Driveway Surface Area		Driveway Surfacing Material	Remarks													
Station	Side	A, B, C, Safety Ramp, or Predetermined*	Case	1 1/2" Dropped Curb	3" Dropped Curb	W	PR	SR		H	Size			Pipe Length	Lt.	Rt.										
			1 or 2	LF	LF	FT	FT	FT		FT	IN			LF	LF	LF	No.	SY	SY	TON						
5+80	L/R																									Existing curb cut, 8" thick PCC, see plan sheet
13+74	L																									Extension of existing drive west of trail, 8" PCC



BURRINGTON GROUP, INC.
Civil Engineering | Land Surveying
105 W. Main Street Manchester, Iowa 52057
Phone 563-927-2434 burringtongroup.com

DRAWN BY: JAW APPROVED BY: JAW
DATE: 12/9/2025 PROJECT NO: 24-150

PROJECT **GRAND AVENUE TRAIL EXTENSION**
TAP-R-4682(629)--8T-28
MANCHESTER, IA

SHEET NAME
TABULATIONS

SHEET NO. OF
C.03 12

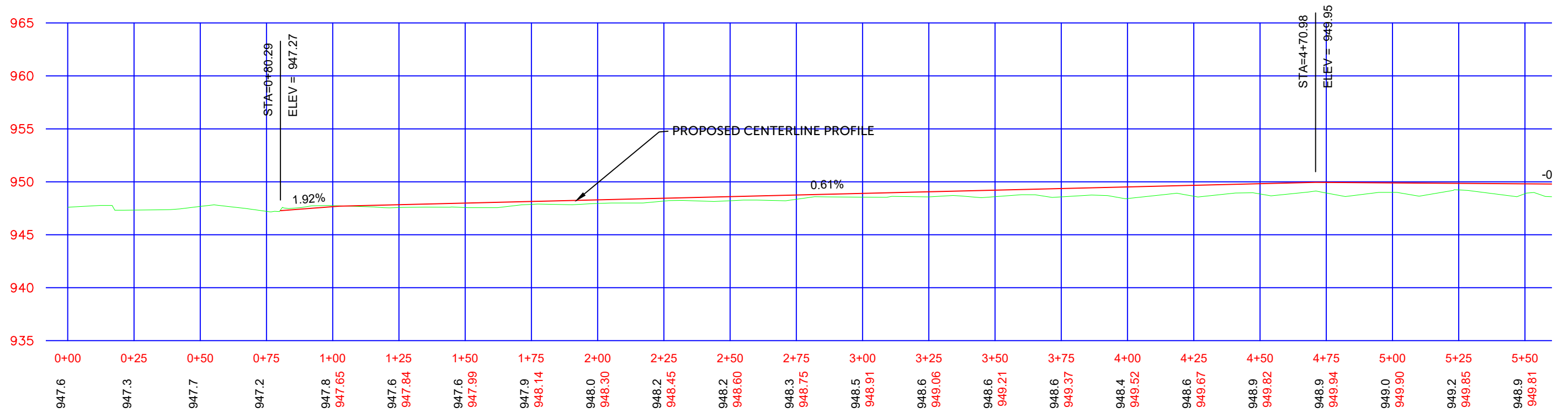
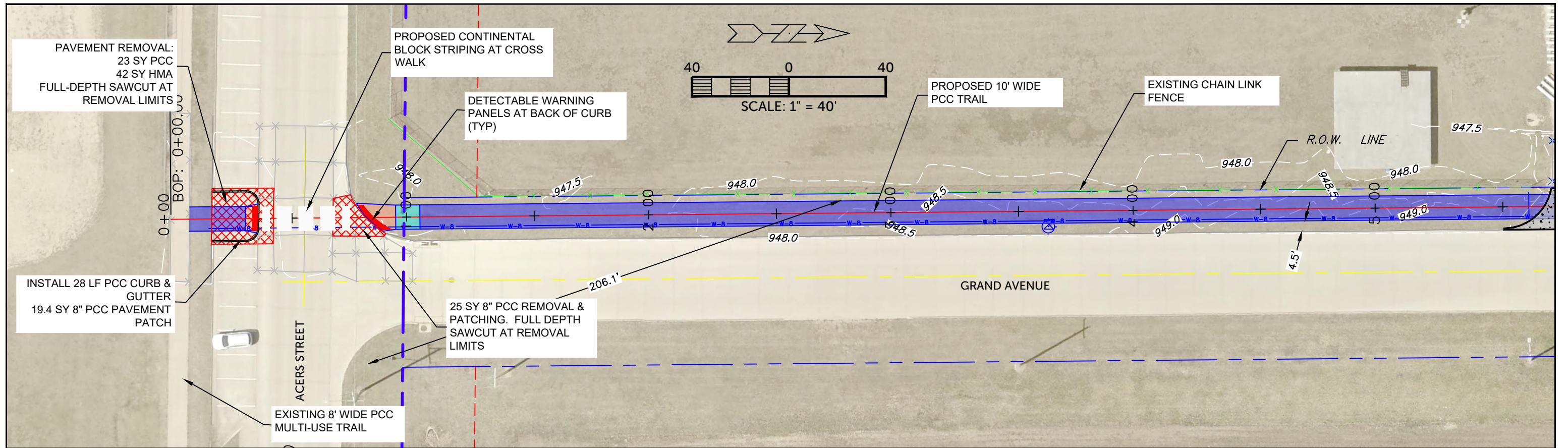

BURRINGTON GROUP, INC.
 Civil Engineering | Land Surveying
 105 W. Main Street Manchester, Iowa 52057
 Phone 563-927-2434 burringtongroup.com

DRAWN BY: JAW APPROVED BY: JAW
 DATE: 12/9/2025 PROJECT NO: 24-150

PROJECT **GRAND AVENUE TRAIL EXTENSION**
TAP-R-4682(629)--8T-28
MANCHESTER, IA

SHEET NAME **TRAIL - STA 0+00**
TO 5+50

SHEET NO. **D.01** OF **12**

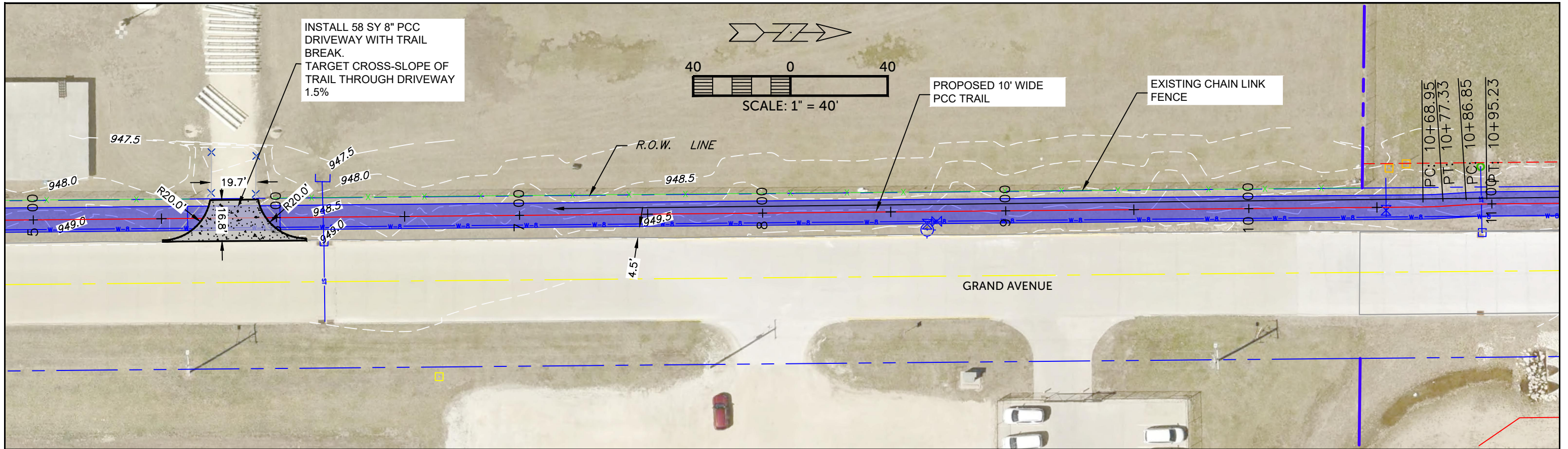

INSTALL 58 SY 8" PCC DRIVEWAY WITH TRAIL BREAK.
TARGET CROSS-SLOPE OF TRAIL THROUGH DRIVEWAY 1.5%

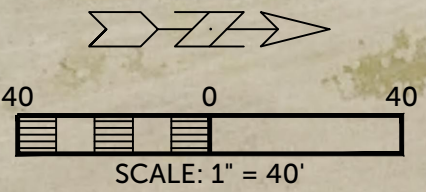

PROPOSED 10' WIDE PCC TRAIL

EXISTING CHAIN LINK FENCE

GRAND AVENUE

PC: 10+68.95
PT: 10+77.33
PC: 10+86.85
PT: 10+95.23

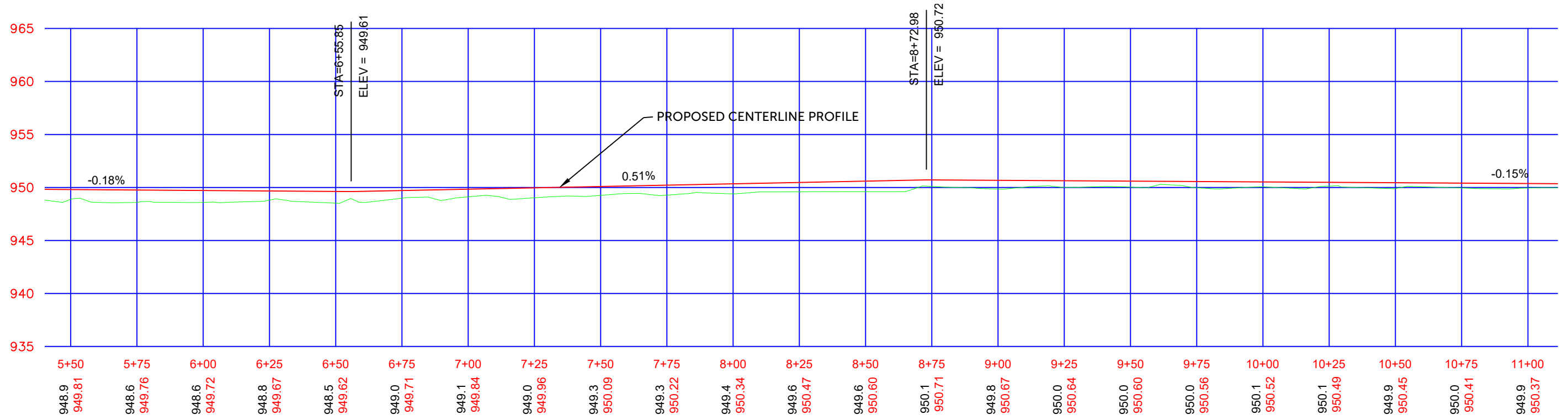

BURRINGTON GROUP, INC.
Civil Engineering | Land Surveying
105 W. Main Street Manchester, Iowa 52057
Phone 563-927-2434 burringtongroup.com

DRAWN BY: JAW APPROVED BY: JAW
DATE: 12/9/2025 PROJECT NO: 24-150

PROJECT **GRAND AVENUE TRAIL EXTENSION**
TAP-R-4682(629)--8T-28
MANCHESTER, IA

SHEET NAME **TRAIL - STA 5+50 TO 11+00**

SHEET NO. **D.02** OF **12**

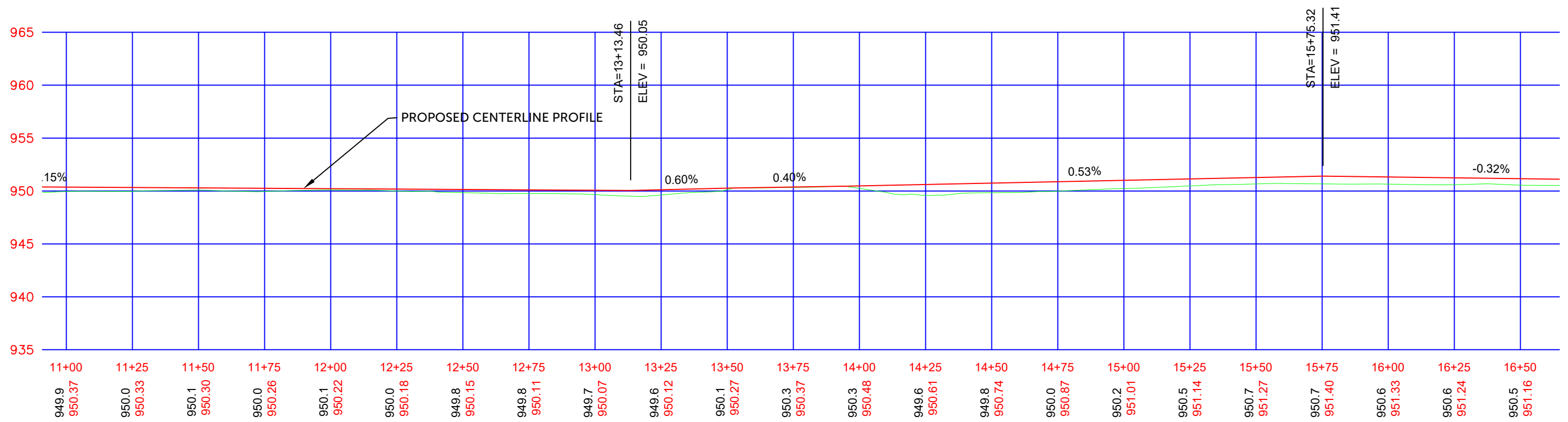
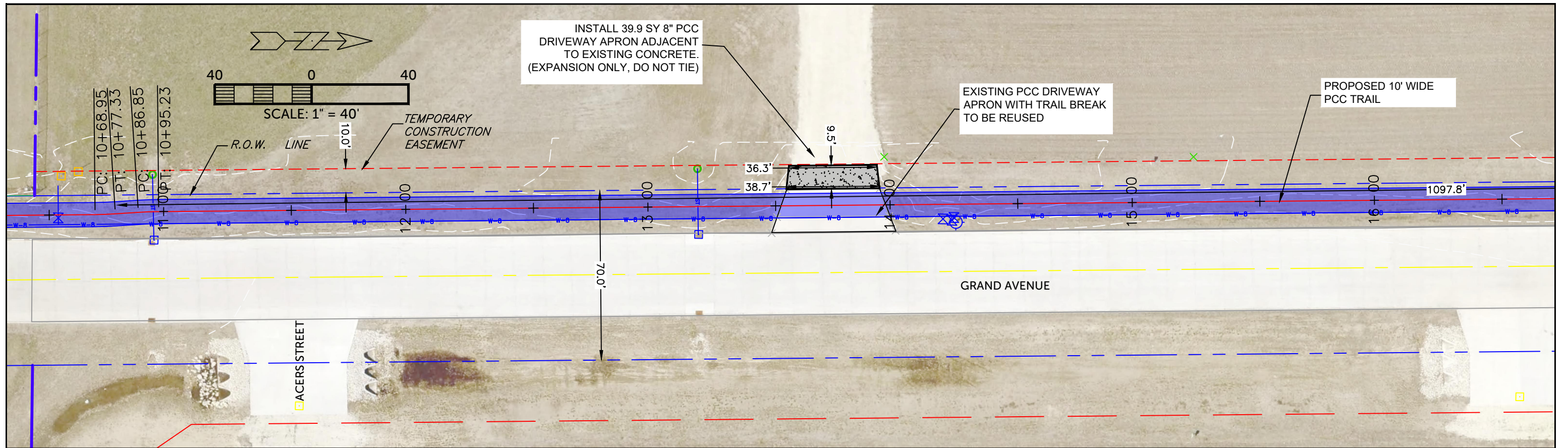

BURRINGTON GROUP, INC.
 Civil Engineering | Land Surveying
 105 W. Main Street Manchester, Iowa 52057
 Phone 563-927-2434 burringtongroup.com

DRAWN BY: JAW APPROVED BY: JAW
 DATE: 12/9/2025 PROJECT NO: 24-150

PROJECT **GRAND AVENUE TRAIL EXTENSION**
TAP-R-4682(629)--8T-28
MANCHESTER, IA

SHEET NAME **TRAIL - STA 11+00**
TO 16.50

SHEET NO. **D.03** OF **12**

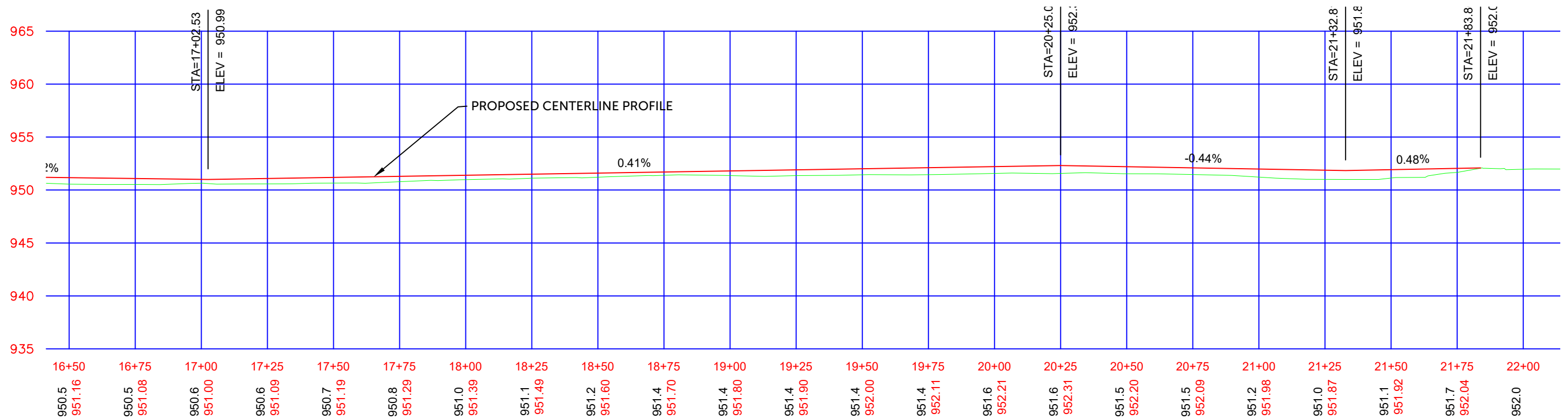
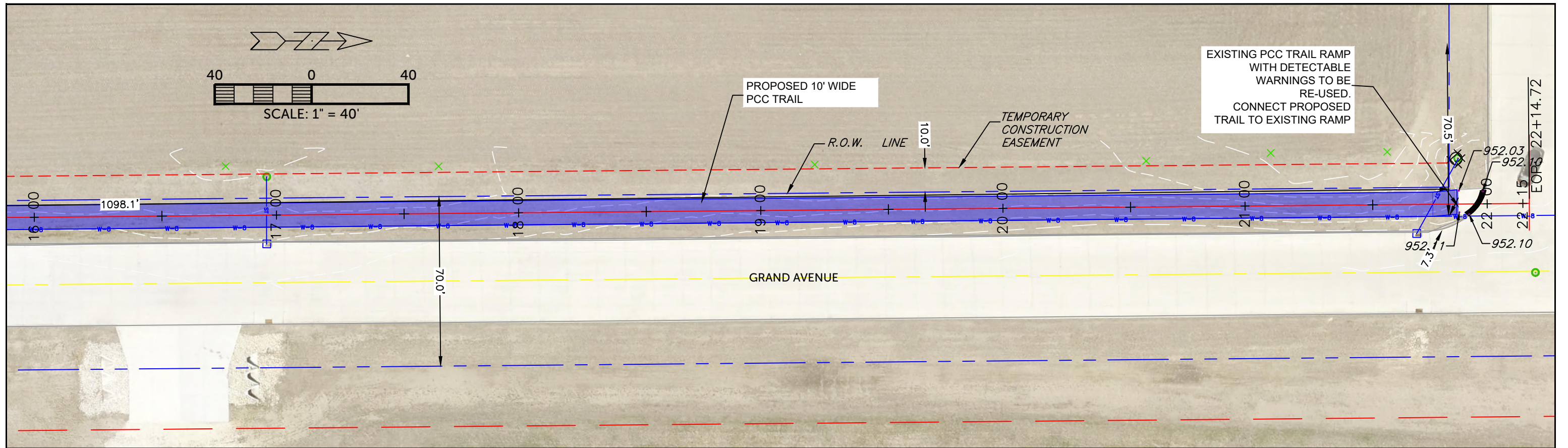

BURRINGTON GROUP, INC.
 Civil Engineering | Land Surveying
 105 W. Main Street Manchester, Iowa 52057
 Phone 563-927-2434 burringtongroup.com

DRAWN BY: JAW APPROVED BY: JAW
 DATE: 12/9/2025 PROJECT NO: 24-150

PROJECT **GRAND AVENUE TRAIL EXTENSION**
TAP-R-4682(629)--8T-28
MANCHESTER, IA

SHEET NAME **TRAIL - STA 16+50**
TO 21+85

SHEET NO. **D.04** OF **12**

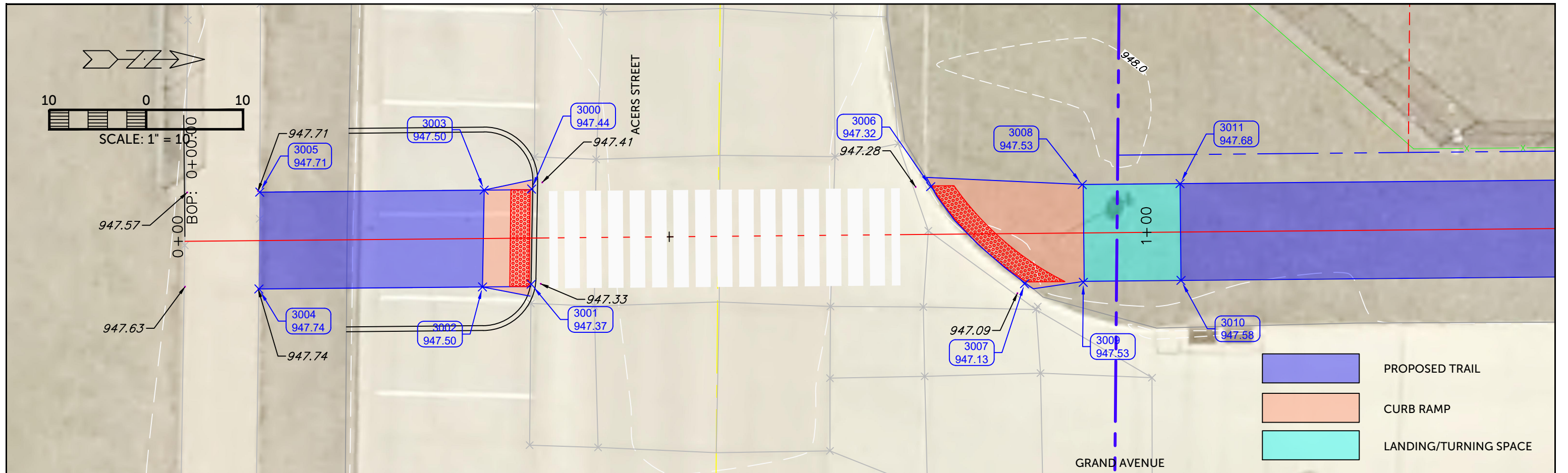

SIDEWALK COMPLIANCE

See S Sheets

* Does not include curb
 Staking required by Contracting Authority per Article 2511.03 of the Standard Specifications.
 Refer to tabulation 113-01 for bid quantities.

Point to Point	Sidewalk Designation	_" PCC Sidewalk (2)	Distance* FT	Δ Elevation FT	Slope %	Acceptable Constructed Range Pos. or Neg.	Staking Required on this Quadrant? (1)	Measured Slope %	Initial s	Remarks	FOR INFORMATION ONLY: VALUES USED TO DETERMINE DESIGNED SLOPES			
											Point	Station	Offset	Elevation
3000	3001 Sidewalk Cross Slope	6	10	0.07	0.7	0.1% to 2.0%					3000			947.44
3000	3003 Ramp Running Slope	6	5	0.06	1.2	0.5% to 8.3%	Yes				3001			947.37
3001	3002 Ramp Running Slope	6	5	0.13	2.6	0.5% to 8.3%	Yes				3002			947.5
3003	3005 Sidewalk Running Slope	5	23	0.21	0.9	0.5% to 5.0%					3003			947.5
3002	3004 Sidewalk Running Slope	5	23	0.24	1.0	0.5% to 5.0%					3004			947.74
3004	3005 Match Existing Cross Slope	5	10	0.03	0.3	0.1% to 2.0%					3005			947.74
											3006			947.32
3006	3007 Sidewalk Cross Slope	6	13.6	0.19	1.4	0.1% to 2.0%					3007			947.13
3006	3008 Ramp Running Slope	6	15.6	0.21	1.3	0.5% to 8.3%	Yes				3008			947.53
3007	3009 Ramp Running Slope	6	5	0.4	8.0	0.5% to 8.3%	Yes				3009			947.53
3008	3011 Landing	5	10	0.15	1.5	0.1% to 2.0%					3010			947.58
3009	3010 Landing	5	10	0.05	0.5	0.1% to 2.0%					3011			947.68
3010	3011 Sidewalk Cross Slope	5	10	0.1	1	0.1% to 2.0%								

BURRINGTON GROUP, INC.
 Civil Engineering | Land Surveying
 105 W. Main Street Manchester, Iowa 52057
 Phone 563-927-2434 burringtongroup.com

DRAWN BY: JAW APPROVED BY: JAW
 DATE: 12/9/2025 PROJECT NO: 24-150

PROJECT **GRAND AVENUE TRAIL EXTENSION**
TAP-R-4682(629)--8T-28
MANCHESTER, IA

SHEET NAME **SIDEWALK PLAN**

SHEET NO. **S.01** OF **12**

Grand Avenue Trail Project

as of 03/17/2026

Estimated Costs

Engineering	\$	64,000
Construction	\$	199,862
Construction Contingency (15%)	\$	29,979
Total	\$	293,841

Proposed Funding

TAP Grant Funds (80% of construction)	\$183,873
Local Option Sales Tax (Walkway portion)	\$109,968
Total	\$293,841

RESOLUTION NO. R-036-2026

Resolution authorizing and approving a Loan Agreement, providing for the issuance of \$2,000,000 General Obligation Corporate Purpose Bonds, Series 2026, and providing for the levy of taxes to pay the same

WHEREAS, the City of Manchester (the “City”), in Delaware County, State of Iowa, proposed to enter into a General Obligation Corporate Purpose Loan Agreement (the “Loan Agreement”), pursuant to the provisions of Section 384.24A of the Code of Iowa, and to borrow money thereunder in a principal amount not to exceed \$2,000,000 for the purpose of paying the costs, to that extent, of (a) constructing street, sidewalk, storm water drainage, sanitary sewer system and water system improvements; and (b) acquiring and installing street lighting, signage and signalization improvements (the “Projects”), and has published notice of the proposed action and has held a hearing thereon on February 23, 2026; and

WHEREAS, a Preliminary Official Statement (the “P.O.S.”) has been prepared to facilitate the sale of the General Obligation Corporate Purpose Bonds, Series 2026 (the “Bonds”) in evidence of the obligation of the City under the Loan Agreement, and the City has made provision for the approval of the P.O.S. and has authorized its use by Speer Financial, Inc., as municipal advisor to the City; and

WHEREAS, pursuant to advertisement of sale, bids for the purchase of the Bonds were received and canvassed on behalf of the City and the substance of such bids noted in the minutes; and

WHEREAS, upon final consideration of all bids, the bid of BOK Financial Securities, Inc., Milwaukee, Wisconsin (the “Purchaser”), was determined to be the best, such bid proposing the lowest interest cost to the City for the Bonds; and

WHEREAS, the Purchaser has executed a certain official bid form/sale agreement (the “Sale Agreement”) with respect to the Loan Agreement and the Bonds, and the City Council has previously approved the Sale Agreement and has made provision for its execution and delivery; and

WHEREAS, the City Council deems it advisable to approve a commitment for municipal bond insurance policy issued by Assured Guaranty Inc. (the “Bond Insurer”) with respect to the Bonds; and

WHEREAS, it is now necessary to make final provision for the approval of the Loan Agreement and to authorize the issuance of the Bonds;

NOW, THEREFORE, Be It Resolved by the City Council of the City of Manchester, Iowa, as follows:

Section 1. The City shall enter into the Loan Agreement with the Purchaser in substantially the form as has been placed on file with the City Council, providing for a loan to the City in the principal amount of \$2,000,000 for the purposes set forth in the preamble hereof.

The Mayor and City Clerk are hereby authorized and directed to sign the Loan Agreement on behalf of the City, and the Loan Agreement is hereby approved.

Furthermore, the Bond Insurer is hereby approved, and the Mayor and the City Clerk (or their acting designees) are hereby authorized to execute and deliver any and all agreements, documents and instruments required related to the issuance of the municipal bond insurance related to the Bonds. The Bond Insurer is a third party beneficiary under this resolution. Any insurance provisions required by the Bond Insurer to be included in this resolution and set forth in its commitment are hereby made a part of this resolution and incorporated herein, and the City Clerk (or designee) is authorized to attach a copy of such insurance provisions, if required, to this resolution.

Section 2. The Bonds, in the aggregate principal amount of \$2,000,000, are hereby authorized to be issued in evidence of the City’s obligations under the Loan Agreement. The Bonds shall be dated April 7, 2026, shall be issued in the denomination of \$5,000 each or any integral multiple thereof and shall mature on June 1 in each of the years, in the respective principal amounts, and bearing interest at the respective rates as follows:

<u>Date</u>	<u>Principal</u>	<u>Interest Rate</u>	<u>Date</u>	<u>Principal</u>	<u>Interest Rate</u>
2027	\$100,000	4.00%	2032	\$210,000	4.00%
2028	\$180,000	4.00%	2033	\$220,000	4.00%
2029	\$185,000	4.00%	2034	\$230,000	4.00%
2030	\$195,000	4.00%	2035	\$235,000	4.00%
2031	\$200,000	4.00%	2036	\$245,000	4.00%

Section 3. UMB Bank, n.a., West Des Moines, Iowa, is hereby designated as the Registrar and Paying Agent for the Bonds and may be hereinafter referred to as the “Registrar” or the “Paying Agent.” The City shall enter into an agreement (the “Registrar/Paying Agent Agreement”) with the Registrar, in substantially the form as has been placed on file with the Council; the Mayor and City Clerk are hereby authorized and directed to sign the Registrar/Paying Agent Agreement on behalf of the City; and the Registrar/Paying Agent Agreement is hereby approved.

The City reserves the right to optionally prepay part or all of the principal of the Bonds maturing in the years 2034 through 2036, inclusive, prior to and in any order of maturity on June 1, 2033, or on any date thereafter upon terms of par and accrued interest. If less than all of the Bonds of any like maturity are to be redeemed, the particular part of those Bonds to be redeemed shall be selected by the Registrar by lot. The Bonds may be called in part in one or more units of \$5,000.

If less than the entire principal amount of any Bond in a denomination of more than \$5,000 is to be redeemed, the Registrar will issue and deliver to the registered owner thereof, upon surrender of such original Bond, a new Bond or Bonds, in any authorized denomination, in a total aggregate principal amount equal to the unredeemed balance of the original Bond. Notice of such redemption as aforesaid identifying the Bond or Bonds (or portion thereof) to be redeemed shall be sent by electronic means or mailed by certified mail to the registered owners thereof at the

addresses shown on the City's registration books not less than 30 days prior to such redemption date. Any notice of redemption may contain a statement that the redemption is conditioned upon the receipt by the Paying Agent of funds on or before the date fixed for redemption sufficient to pay the redemption price of the Bonds called for redemption, and that if funds are not available, such redemption shall be cancelled by written notice to the owners of the Bonds called for redemption in the same manner as the original redemption notice was sent. All of such Bonds as to which the City reserves and exercises the right of redemption and as to which notice as aforesaid shall have been given and for the redemption of which funds are duly provided, shall cease to bear interest on the redemption date.

Accrued interest on the Bonds shall be payable semiannually on the first day of June and December in each year, commencing December 1, 2026. Interest shall be calculated on the basis of a 360-day year comprised of twelve 30-day months. Payment of interest on the Bonds shall be made to the registered owners appearing on the registration books of the City at the close of business on the fifteenth day of the month next preceding the interest payment date and shall be paid to the registered owners at the addresses shown on such registration books. Principal of the Bonds shall be payable in lawful money of the United States of America to the registered owners or their legal representatives upon presentation and surrender of the Bond or Bonds at the office of the Paying Agent.

The Bonds shall be executed on behalf of the City with the official manual or facsimile signature of the Mayor and attested with the official manual or facsimile signature of the City Clerk, and shall be fully registered Bonds without interest coupons. In case any officer whose signature or the facsimile of whose signature appears on the Bonds shall cease to be such officer before the delivery of the Bonds, such signature or such facsimile signature shall nevertheless be valid and sufficient for all purposes, the same as if such officer had remained in office until delivery.

The Bonds shall not be valid or become obligatory for any purpose until the Certificate of Authentication thereon shall have been signed by the Registrar.

The Bonds shall be fully registered as to principal and interest in the names of the owners on the registration books of the City kept by the Registrar, and after such registration, payment of the principal thereof and interest thereon shall be made only to the registered owners or their legal representatives or assigns. Each Bond shall be transferable only upon the registration books of the City upon presentation to the Registrar, together with either a written instrument of transfer satisfactory to the Registrar or the assignment form thereon completed and duly executed by the registered owner or the duly authorized attorney for such registered owner.

The record and identity of the owners of the Bonds shall be kept confidential as provided by Section 22.7 of the Code of Iowa.

Section 4. Notwithstanding anything above to the contrary, the Bonds shall be issued initially as Depository Bonds, with one fully registered Bond for each maturity date, in principal amounts equal to the amount of principal maturing on each such date, and registered in the name of Cede & Co., as nominee for The Depository Trust Company, New York, New York ("DTC"). On original issue, the Bonds shall be deposited with DTC for the purpose of maintaining a book-

entry system for recording the ownership interests of its participants and the transfer of those interests among its participants (the “Participants”). In the event that DTC determines not to continue to act as securities depository for the Bonds or the City determines not to continue the book-entry system for recording ownership interests in the Bonds with DTC, the City will discontinue the book-entry system with DTC. If the City does not select another qualified securities depository to replace DTC (or a successor depository) in order to continue a book-entry system, the City will register and deliver replacement Bonds in the form of fully registered certificates, in authorized denominations of \$5,000 or integral multiples of \$5,000, in accordance with instructions from Cede & Co., as nominee for DTC. In the event that the City identifies a qualified securities depository to replace DTC, the City will register and deliver replacement Bonds, fully registered in the name of such depository, or its nominee, in the denominations as set forth above, as reduced from time to time prior to maturity in connection with redemptions or retirements by call or payment, and in such event, such depository will then maintain the book-entry system for recording ownership interests in the Bonds.

Ownership interests in the Bonds may be purchased by or through Participants. Such Participants and the persons for whom they acquire interests in the Bonds as nominees will not receive certificated Bonds, but each such Participant will receive a credit balance in the records of DTC in the amount of such Participant’s interest in the Bonds, which will be confirmed in accordance with DTC’s standard procedures. Each such person for which a Participant has an interest in the Bonds, as nominee, may desire to make arrangements with such Participant to have all notices of redemption or other communications of the City to DTC, which may affect such person, forwarded in writing by such Participant and to have notification made of all interest payments.

The City will have no responsibility or obligation to such Participants or the persons for whom they act as nominees with respect to payment to or providing of notice for such Participants or the persons for whom they act as nominees.

As used herein, the term “Beneficial Owner” shall hereinafter be deemed to include the person for whom the Participant acquires an interest in the Bonds.

DTC will receive payments from the City, to be remitted by DTC to the Participants for subsequent disbursement to the Beneficial Owners. The ownership interest of each Beneficial Owner in the Bonds will be recorded on the records of the Participants whose ownership interest will be recorded on a computerized book-entry system kept by DTC.

When reference is made to any action which is required or permitted to be taken by the Beneficial Owners, such reference shall only relate to those permitted to act (by statute, regulation or otherwise) on behalf of such Beneficial Owners for such purposes. When notices are given, they shall be sent by the City to DTC, and DTC shall forward (or cause to be forwarded) the notices to the Participants so that the Participants can forward the same to the Beneficial Owners.

Beneficial Owners will receive written confirmations of their purchases from the Participants acting on behalf of the Beneficial Owners detailing the terms of the Bonds acquired. Transfers of ownership interests in the Bonds will be accomplished by book entries made by DTC and the Participants who act on behalf of the Beneficial Owners. Beneficial Owners will not

receive certificates representing their ownership interest in the Bonds, except as specifically provided herein. Interest and principal will be paid when due by the City to DTC, then paid by DTC to the Participants and thereafter paid by the Participants to the Beneficial Owners.

Section 5. The Bonds shall be in substantially the following form:

(Form of Bond)

UNITED STATES OF AMERICA
STATE OF IOWA
DELAWARE COUNTY
CITY OF MANCHESTER

GENERAL OBLIGATION CORPORATE PURPOSE BOND, SERIES 2026

No. _____ \$ _____

RATE	MATURITY DATE	BOND DATE	CUSIP
_____%	June 1, _____	April 7, 2026	562213 ____

The City of Manchester (the “City”), in Delaware County, State of Iowa, for value received, promises to pay on the maturity date of this Bond to

Cede & Co.
New York, New York

or registered assigns, the principal sum of

THOUSAND DOLLARS

in lawful money of the United States of America upon presentation and surrender of this Bond at the office of UMB Bank, n.a., West Des Moines, Iowa (hereinafter referred to as the “Registrar” or the “Paying Agent”), with interest on said sum, until paid, at the rate per annum specified above from the date of this Bond, or from the most recent interest payment date on which interest has been paid, on June 1 and December 1 of each year, commencing December 1, 2026 except as the provisions hereinafter set forth with respect to redemption prior to maturity may be or become applicable hereto. Interest on this Bond is payable to the registered owner appearing on the registration books of the City at the close of business on the fifteenth day of the month next preceding the interest payment date, and shall be paid to the registered owner at the address shown on such registration books. Interest shall be calculated on the basis of a 360-day year comprised of twelve 30-day months.

This Bond shall not be valid or become obligatory for any purpose until the Certificate of Authentication hereon shall have been signed by the Registrar.

This Bond is one of a series of General Obligation Corporate Purpose Bonds, Series 2026 (the “Bonds”) issued by the City to evidence its obligation under a certain loan agreement, dated as of April 7, 2026 (the “Loan Agreement”), entered into by the City for the purpose of paying the cost, to that extent, of: (a) constructing street, sidewalk, storm water drainage, sanitary sewer system and water system improvements; and (b) acquiring and installing street lighting, signage and signalization improvements.

The Bonds are issued pursuant to and in strict compliance with the provisions of Chapters 76 and 384 of the Code of Iowa, 2025, and all other laws amendatory thereof and supplemental thereto, and in conformity with a resolution of the City Council, adopted on March 23, 2026, authorizing and approving the Loan Agreement and providing for the issuance and securing the payment of the Bonds (the “Resolution”), and reference is hereby made to the Resolution and the Loan Agreement for a more complete statement as to the source of payment of the Bonds and the rights of the owners of the Bonds.

The City reserves the right to optionally prepay part or all of the principal of the Bonds maturing in the years 2034 through 2036, inclusive, prior to and in any order of maturity on June 1, 2033, or on any date thereafter upon terms of par and accrued interest. If less than all of the Bonds of any like maturity are to be redeemed, the particular part of those Bonds to be redeemed shall be selected by the Registrar by lot. The Bonds may be called in part in one or more units of \$5,000.

If less than the entire principal amount of any Bond in a denomination of more than \$5,000 is to be redeemed, the Registrar will issue and deliver to the registered owner thereof, upon surrender of such original Bond, a new Bond or Bonds, in any authorized denomination, in a total aggregate principal amount equal to the unredeemed balance of the original Bond. Notice of such redemption as aforesaid identifying the Bond or Bonds (or portion thereof) to be redeemed shall be sent by electronic means or by certified mail to the registered owners thereof at the addresses shown on the City's registration books not less than 30 days prior to such redemption date. All of such Bonds as to which the City reserves and exercises the right of redemption and as to which notice as aforesaid shall have been given and for the redemption of which funds are duly provided, shall cease to bear interest on the redemption date.

This Bond is fully negotiable but shall be fully registered as to both principal and interest in the name of the owner on the books of the City in the office of the Registrar, after which no transfer shall be valid unless made on said books and then only upon presentation of this Bond to the Registrar, together with either a written instrument of transfer satisfactory to the Registrar or the assignment form hereon completed and duly executed by the registered owner or the duly authorized attorney for such registered owner.

The City, the Registrar and the Paying Agent may deem and treat the registered owner hereof as the absolute owner for the purpose of receiving payment of or on account of principal hereof, premium, if any, and interest due hereon and for all other purposes, and the City, the Registrar and the Paying Agent shall not be affected by any notice to the contrary.

And It Is Hereby Certified and Recited that all acts, conditions and things required by the laws and Constitution of the State of Iowa, to exist, to be had, to be done or to be performed precedent to and in the issue of this Bond were and have been properly existent, had, done and performed in regular and due form and time; that provision has been made for the levy of a sufficient continuing annual tax on all the taxable property within the City for the payment of the principal of and interest on this Bond as the same will respectively become due; and that the total indebtedness of the City, including this Bond, does not exceed any constitutional or statutory limitations.

IN TESTIMONY WHEREOF, the City of Manchester, Iowa, by its City Council, has caused this Bond to be executed with the duly authorized facsimile signature of its Mayor and attested with the duly authorized facsimile signature of its City Clerk, as of April 7, 2026.

CITY OF MANCHESTER, IOWA

By (DO NOT SIGN)
Mayor

Attest:

(DO NOT SIGN)
City Clerk

Registration Date: (Registration Date)

REGISTRAR’S CERTIFICATE OF AUTHENTICATION

This Bond is one of the Bonds described in the within-mentioned Resolution.

UMB Bank, n.a.
West Des Moines, Iowa
Registrar

By (Authorized Signature)
Authorized Officer

STATEMENT OF INSURANCE

Assured Guaranty Inc. (“AG”) has delivered its municipal bond insurance policy (the “Policy”) with respect to the scheduled payments due of principal of and interest on this Bond to UMB Bank, n.a., West Des Moines, Iowa, or its successor, as paying agent for the Bonds (the "Paying Agent"). Said Policy is on file and available for inspection at the principal office of the Paying Agent and a copy thereof may be obtained from AG or the Paying Agent. All payments required to be made under the Policy shall be made in accordance with the provisions thereof. The owner of this Bond acknowledges and consents to the subrogation rights of AG as more fully set forth in the Policy.

ABBREVIATIONS

The following abbreviations, when used in this Bond, shall be construed as though they were written out in full according to applicable laws or regulations:

- | | | | | |
|---------|---|--|---------------------------------------|---------------|
| TEN COM | - | as tenants in common | UTMA | _____ |
| TEN ENT | - | as tenants by the entireties | | (Custodian) |
| JT TEN | - | as joint tenants with right of survivorship and not as tenants in common | As Custodian for | _____ (Minor) |
| | | | under Uniform Transfers to Minors Act | _____ (State) |

Additional abbreviations may also be used though not in the list above.

ASSIGNMENT

For valuable consideration, receipt of which is hereby acknowledged, the undersigned assigns this Bond to

(Please print or type name and address of Assignee)

PLEASE INSERT SOCIAL SECURITY OR OTHER IDENTIFYING NUMBER OF ASSIGNEE

and does hereby irrevocably appoint _____, Attorney, to transfer this Bond on the books kept for registration thereof with full power of substitution.

Dated: _____

Signature guaranteed:

(Signature guarantee must be provided in accordance with the prevailing standards and procedures of the Registrar and Transfer Agent. Such standards and procedures may require signatures to be guaranteed by certain eligible guarantor institutions that participate in a recognized signature guarantee program.)

NOTICE: The signature to this Assignment must correspond with the name of the registered owner as it appears on this Bond in every particular, without alteration or enlargement or any change whatever.

Section 6. The Bonds shall be executed as herein provided as soon after the adoption of this resolution as may be possible, and thereupon they shall be delivered to the Registrar for registration, authentication and delivery to or on behalf of the Purchaser, upon receipt of the loan proceeds (\$2,119,518.55) (the “Loan Proceeds”), including the net original issue reoffering premium (\$119,518.55), and all action heretofore taken in connection with the Loan Agreement is hereby ratified and confirmed in all respects.

A portion of the Loan Proceeds (\$20,000) shall be retained by the Purchaser as the underwriter’s discount.

A portion of the Loan Proceeds (\$2,058,903.55) (the “Project Proceeds”) received from the sale of the Bonds, shall be deposited in a dedicated fund (the “Project Fund”), which is hereby created, to be used for the payment of costs of the Projects and to the extent that Project Proceeds remain after the full payment of the costs of the Projects, such Proceeds, shall be transferred to the Debt Service Fund for the payment of interest on the Bonds.

A portion of the Loan Proceeds (\$14,000) received from the sale of the Bonds shall be used to pay the bond insurance premium to the Bond Insurer.

The remainder of the Loan Proceeds (\$26,615) (the “Cost of Issuance Proceeds”), received from the sale of the Bonds shall be deposited in the Project Fund, and shall be used for the payment of costs of issuance of the Bonds, and to the extent that Cost of Issuance Proceeds remain after the full payment of the costs of issuance of the Bonds, such Cost of Issuance Proceeds shall be transferred to the Debt Service Fund for the payment of interest on the Bonds.

The City shall keep a detailed and segregated accounting of the expenditure of, and investment earnings on, the Loan Proceeds to ensure compliance with the requirements of the Internal Revenue Code, as hereinafter defined.

Section 7. For the purpose of providing for the levy and collection of a direct annual tax sufficient to pay the principal of and interest on the Bonds as the same become due, there is hereby ordered levied on all the taxable property in the City the following direct annual tax for collection in each of the following fiscal years:

For collection in the fiscal year beginning July 1, 2026,
sufficient to produce the net annual sum of \$192,000;

For collection in the fiscal year beginning July 1, 2027,
sufficient to produce the net annual sum of \$256,000;

For collection in the fiscal year beginning July 1, 2028,
sufficient to produce the net annual sum of \$253,800;

For collection in the fiscal year beginning July 1, 2029,
sufficient to produce the net annual sum of \$256,400;

For collection in the fiscal year beginning July 1, 2030,
sufficient to produce the net annual sum of \$253,600;

For collection in the fiscal year beginning July 1, 2031,
sufficient to produce the net annual sum of \$255,600;

For collection in the fiscal year beginning July 1, 2032,
sufficient to produce the net annual sum of \$257,200;

For collection in the fiscal year beginning July 1, 2033,
sufficient to produce the net annual sum of \$258,400;

For collection in the fiscal year beginning July 1, 2034,
sufficient to produce the net annual sum of \$254,200; and

For collection in the fiscal year beginning July 1, 2035,
sufficient to produce the net annual sum of \$254,800.

Section 8. A certified copy of this resolution shall be filed with the County Auditor of Delaware County, and the County Auditor is hereby instructed to enter for collection and assess the tax hereby authorized. When annually entering such taxes for collection, the County Auditor shall include the same as a part of the tax levy for Debt Service Fund purposes of the City and when collected, the proceeds of the taxes shall be converted into the Debt Service Fund of the City and set aside therein as a special account to be used solely and only for the payment of the principal of and interest on the Bonds hereby authorized and for no other purpose whatsoever.

Pursuant to the provisions of Section 76.4 of the Code of Iowa, each year while the Bonds remain outstanding and unpaid, any funds of the City which may lawfully be applied for such purpose may be appropriated, budgeted and, if received, used for the payment of the principal of and interest on the Bonds as the same become due, and if so appropriated, the taxes for any given fiscal year as provided for in Section 7 of this Resolution, shall be reduced by the amount of such alternate funds as have been appropriated for said purpose and evidenced in the City's budget.

Section 9. The interest or principal and both of them falling due in any year or years shall, if necessary, be paid promptly from current funds on hand in advance of taxes levied and when the taxes shall have been collected, reimbursement shall be made to such current funds in the sum thus advanced.

Section 10. It is the intention of the City that interest on the Bonds be and remain excluded from gross income for federal income tax purposes pursuant to the appropriate provisions of the Internal Revenue Code of 1986, as amended, and the Treasury Regulations in effect with respect thereto (all of the foregoing herein referred to as the "Internal Revenue Code"). In furtherance thereof, the City covenants to comply with the provisions of the Internal Revenue Code as they may from time to time be in effect or amended and further covenants to comply with the applicable future laws, regulations, published rulings and court decisions as may be necessary to insure that the interest on the Bonds will remain excluded from gross income for federal income tax purposes. Any and all of the officers of the City are hereby authorized and directed to take any and all actions as may be necessary to comply with the covenants herein contained.

The City hereby designates the Bonds as “Qualified Tax Exempt Obligations” as that term is used in Section 265(b)(3)(B) of the Internal Revenue Code.

Section 11. The Securities and Exchange Commission (the “SEC”) has promulgated certain amendments to Rule 15c2-12 under the Securities Exchange Act of 1934 (17 C.F.R. § 240.15c2-12) (the “Rule”) that make it unlawful for an underwriter to participate in the primary offering of municipal securities in a principal amount of \$1,000,000 or more unless, before submitting a bid or entering into a purchase contract for the bonds, an underwriter has reasonably determined that the issuer or an obligated person has undertaken in writing for the benefit of the bondholders to provide certain disclosure information to prescribed information repositories on a continuing basis or unless and to the extent the offering is exempt from the requirements of the Rule.

On the date of issuance and delivery of the Bonds, the City will execute and deliver a Continuing Disclosure Certificate pursuant to which the City will undertake to comply with the Rule. The City covenants and agrees that it will comply with and carry out the provisions of the Continuing Disclosure Certificate. Any and all of the officers of the City are hereby authorized and directed to take any and all actions as may be necessary to comply with the Rule and the Continuing Disclosure Certificate.

Section 12. All resolutions or parts thereof in conflict herewith are hereby repealed to the extent of such conflict.

Section 13. This resolution shall be in full force and effect immediately upon its approval and adoption, as provided by law.

Passed and approved March 23, 2026.

Mayor

Attest:

City Clerk



LETTER OF INTENT TO PARTICIPATE AND SUPPORT

The City of Manchester hereby expresses its support for the building project at 116 South Franklin Street and the associated rehabilitation application to the Iowa Economic Development Authority for the 2026 Community Catalyst Building Remediation Program Grant.

The City not only endorses the proposed design and business plans for this venture, as reflected in the previously submitted City Council minutes from December 2025, but has also committed financial support through Acquisition and Design Assistance Grants, Façade, Awning and Interior Grants, as well as a Second Story Loan for this project.

Furthermore, representatives of the City Council, along with local building and/or fire code officials responsible for project inspection, have reviewed the proposed project. The City affirms that all historically significant properties included in this application will comply with the Secretary of the Interior's Standards for the rehabilitation of historic properties.

Connie Behnken, Mayor

Date: _____

Arron Wulfekuhle, Subrecipient

Date: _____

PROJECT ASSURANCES:

Name of Property Owner: RAMM Properties LLC

Address of Project Property: 116 S Franklin Street

As rightful owner(s), developer(s), and/or responsible entity(s), we: *(check boxes to confirm)*

- Agree to the submission of the Iowa Economic Development Authority (IEDA) Grant application for the benefit of the above-named property/project.
- Agree to all terms and conditions defined in the IEDA Grant application.
- Agree to provide the specified cash match documented in the application.
- Understand that grant funds are made as a reimbursement and understand that we must complete the proposed scope of work for the project before receiving final reimbursement of grant funds. We understand a representative of IEDA will conduct an on-site final inspection of the project before approval of final reimbursement payment. We agree to work through the local government program for reimbursement requests.
- Agree to notify local grant recipient AND IEDA regarding changes in scope of work that may occur during construction that vary from the proposed plans submitted in the grant application.
- Understand that any significant deviation/changes from the submitted proposed designs without approval from IEDA may jeopardize the grant award.
- Agree to abide by state and federal civil rights requirements which bars discrimination against any employee, applicant for employment, or any person participating in any sponsored program on the basis of race, creed, color, national origin, religion, sex, age, physical or mental disability.
- Agree to maintain safe and sanitary working conditions and compensation for employment no less than minimum wage.
- Understand that IEDA reserves the right to use information relevant to the project in case studies, program marketing, etc.
- I am aware of the Secretary of the Interior's [Standards for the Treatment of Historic Properties](#) and it is our desire to follow best practices for preservation and rehabilitation throughout the project.
- I agree to conform with the [Americans with Disability Act](#).
- I agree to conform with all local building codes and regulations.
- I agree to conform with all local design guidelines and design review processes (if applicable).

By signing this Project Assurances document, we certify the information presented above, and in the application and attachments, to be true and correct to the best of the entity's knowledge.

Property Owner:

City Representative (grant recipient):

Type/Print Name and Title

Type/Print Name and Title

Signature:

Signature:

Date: _____

Date: _____

ORDINANCE NO. 002-2026
ORDINANCE AMENDING THE CITY CODE OF THE CITY OF MANCHESTER, IOWA BY AMENDING CHAPTER 55
ANIMAL PROTECTION & CONTROL

BE IT ENACTED by the City Council of the City of Manchester, Iowa:

SECTION 1. SECTION MODIFIED. Chapter 55 “Animal Protection and Control” of the City Code of the City of Manchester, Iowa is hereby amended by adding section 55.22 “Animal Waste Removal” as follows:

55.22 ANIMAL WASTE REMOVAL.

It is prohibited for any person to permit or allow an animal owned by that person or under that person's custody or control to defecate upon public property, park property, public right-of-way, or the property of another unless appropriately cleaned up pursuant to this section. It shall be the duty of every person owning or having the custody or control of an animal to clean up, remove, and dispose of the feces deposited by such animal upon public property, park property, public right-of-way or the property of another. Failure to do so shall constitute a misdemeanor. Any person shall be deemed to have permitted the animal to discharge feces upon any public or private property if the owner does not immediately thereafter, without leaving/continuing from the location, take steps to remove and clean up the feces from the property. In addition, all persons shall keep all structures, pens, coops or yards wherein animals are confined clean, devoid of vermin, and free of odors arising from feces.

SECTION 2. SEVERABILITY CLAUSE. If any section, provision or part of this ordinance shall be adjudged invalid or unconstitutional, such adjudication shall not affect the validity of the ordinance as a whole or any section, provision or part thereof not adjudged invalid or unconstitutional.

SECTION 3. WHEN EFFECTIVE. This ordinance shall be in effect after its passage, approval and publication as provided by law.

Passed and approved this _____.

Connie Behnken, Mayor

ATTEST:

Erin Learn, City Clerk

ORDINANCE NO. 003-2026

AN ORDINANCE AMENDING THE CITY CODE OF THE CITY OF MANCHESTER, IOWA, BY ADDING A PROVISION PERTAINING TO PARKING VIOLATIONS

BE IT ENACTED by the City Council of the City of Manchester, Iowa:

SECTION 1. Section 70.03 of the City Code of the City of Manchester, Iowa, is amended as follows:

70.03 PARKING VIOLATIONS: ALTERNATE

Uncontested violations of parking restrictions imposed by this Code of Ordinances may be charged upon a simple notice of a fine payable at the office of the City Clerk. The simple notice of a fine shall be in the amount of twenty dollars (\$20.00) for all violations except improper use of a persons with disabilities parking permit, snow route parking and alternate side parking. If such fine is not paid within thirty (30) days, it shall be increased by ten dollars (\$10.00). The simple notice of a fine for improper use of a persons with disabilities parking permit is one hundred and ten dollars (\$110.00). Violations of snow route parking and alternate side parking regulations shall initially result in a fifty dollar (\$50.00) fine.

SECTION 2. SEVERABILITY CLAUSE. If any section, provision or part of this ordinance shall be adjudged invalid or unconstitutional, such adjudication shall not affect the validity of the ordinance as a whole or any section, provision or part thereof not adjudged invalid or unconstitutional.

SECTION 3. WHEN EFFECTIVE. This ordinance shall be in effect from and after its final passage, approval and publication as provided by law.

Passed and approved _____.

Connie Behnken, Mayor

ATTEST:

Erin Learn, City Clerk

From: [ethan_uhrig](#)
To: [Erin Learn](#)
Subject: Letter to Request Permission For Chickens
Date: Wednesday, March 18, 2026 2:30:38 PM

Dear City Council Members,

My name is Ethan Uhrig. I am requesting permission to keep 6 or 8 chickens if possible, at 500 East Prospect Street. The purpose of them would be for collecting eggs for my family. Thank you for your consideration.

Signed,

Ethan Uhrig

563-929-1765

500 E Prospect Street
Manchester, Iowa 52057

